



w e t s o u n d s ®



OEM PARTNER
RESOURCE



THE WET SOUNDS™ STORY

Since the beginning, it has been Wet Sounds' mission to deliver a CLEAR, LOUD and LIVE audio experience to remember in the most demanding environments. Wet Sounds continues to be the undisputed leader in high performance audio products - aspiring to not only meet, but exceed our customers expectations. We never follow the crowd. We seek to push the boundaries of what is possible through constant innovation and technological advancement. Our goal will never change - build the highest performance, element-proof audio products!

Wet Sounds is more than just an audio company. We are a lifestyle. We are the Wet Life!



INDEX

History of Wet Sounds	6-7	SURFACE MOUNT SPEAKERS	
Manufacturing Capabilities	8	REV 5x7, REV 6x9	41
Intellectual Property	9	SHALLOW MOUNT SPEAKERS	42
In House Product Development	10-11	SUBWOOFERS	
SOURCE UNITS		Zero Subwoofers	43
WS-BB-10	12-13	REVO 12-XXX, 15-XXX	44-45
WS-MC-1	14-15	REVO FA/HP	46-47
WS-MC-20	16-17	RECON Subwoofers	48
WS-MC-2	18-19	PASSIVE SUBWOOFER ENCLOSURES	49
WS-MC-5	20-21	SOUNDBARS	
SOURCE UNIT ACCESSORIES		Stealth XT Series	50-51
WS-G2-CTR, TR	22-23	POWERED SUBWOOFERS	52
OE-CAN-TR	24	AMPLIFIERS	
WS-MC-TR-MINI	25	HTM Series	53
WS-MC-TR	26-27	Sinister Series	54
BLUETOOTH CONTROLLERS	28-29	SYN-DX Series	55
TOWER SPEAKERS		HTX-Series	56
REV 10/12 HD	30-31	STX Micro Series	57
REV8™ REV10™	32	OEM Amplifiers	58
ICON 8	33	AMP Board	59
RECON Pods	34	ZERO ENC	60
COAXIAL SPEAKERS		SEND/RECEIVE KITS	61
ZERO Series	36-37	GOLF CART ACCESSORIES	62-63
REVO V3	38-39	JEEP AUDIO KIT	64-65
RECON COAXIAL	40	SHIVR COOLERS	66-67
		WET WIRE™	68-71



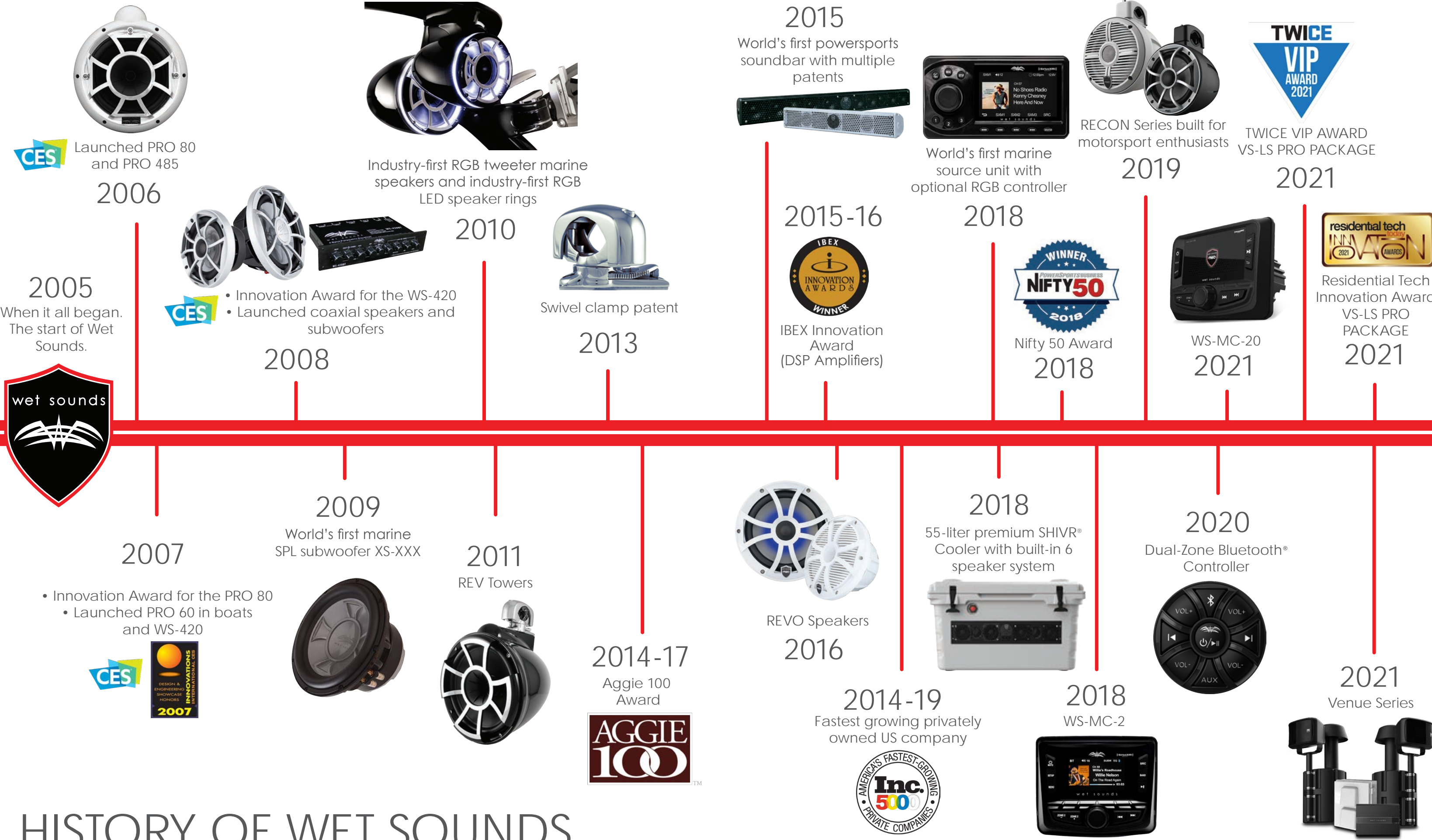

HISTORY OF WET SOUNDS

MANUFACTURING FACILITY | CAPABILITIES

Wet Sounds audio production is Vertically Integrated. Our production facility in Brazil produces every part of the speaker including the frame, cone/surround, spider, tweeter, voice coil, crossover and final assembly. Our production facility in China has in-house production of certain parts including the frame, crossover and final assembly.

Additional Facility Details

Injection mold machines	Brazil 15	China 20
Assembly lines	Brazil 2	China 2
Final assembly lines	Brazil 3	China 2
In house tooling	Brazil ✓	China ✓
Anechoic Chamber	Brazil ✓	China ✓

Manufacturing Capabilities

- Speakers
- Subwoofers
- Amplifiers
- Source Units
- Metal Stamping
- Metal Extrusion
- Thermo Forming
- Injection Molding
- Rotational Molding
- Precision Casting for Stainless Steel
- Die Casting for Aluminum, Electronics, Audio Components and much more

In-House Testing

- UV
- Salt spray
- Vibration
- Drop testing
- EMI
- Environmental Temperatures:
 - Extreme heat
 - Extreme cold
- 3rd party independent testing also available

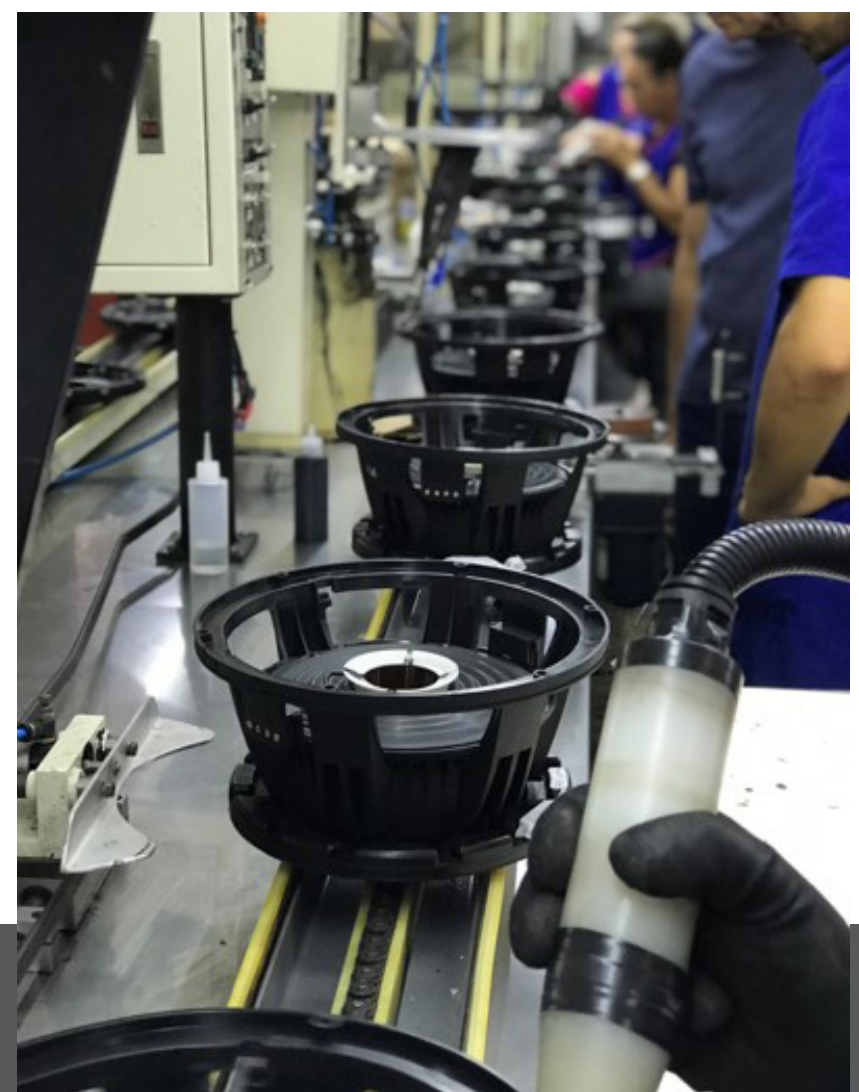

Assembly line in Brazil

INTELLECTUAL PROPERTY

Wet Sounds maintains a strong intellectual portfolio that includes patents, patents pending, and federally registered trademarks.

Wet Sounds owns the patent for our swivel clamp: U.S. Utility Patent No. 8,568,162B1 - Mountable Loudspeaker Assemblies and Clamps.

Wet Sounds product design concepts such as DSP-integrated amplifiers and RGB LED control from the head unit are all Wet Sounds design ideas that have changed the way OEM marine audio systems are used.

Wet Sounds Patents:

- U.S. Utility Patent No. 8,568,162B1; Mountable Loudspeaker Assemblies and Clamps
- U.S. Utility Patent No.: US 9,469,254B1, 10,486,613B2; Speaker Systems for Off-Road Vehicles, ATV's, UTV's, Watercraft and Motorcycles
- U.S. Design Patent No. D757,686S1; Speaker Sound Bar With Side Mounts
- U.S. Design Patent No. D757,687S1; Speaker Sound Bar
- U.S. Design Patent No. D756,962S1; Speaker Sound Bar with Bolt on Mounts
- U.S. Design Patent No. D756,963S1; Speaker Sound Bar with Track Mounts
- U.S. Design Patent No. D756,961S1; Speaker Sound Bar with an LED Display
- U.S. Design Patent No. D756,964S1; Speaker Sound Bar with Multiple Mount Options
- U.S. Design Patent No. 2017,002,672,5A1; Speaker System for Off-road Vehicles, ATV's, UTV's, Watercraft and Motorcycles

Wet Sounds Proprietary Technology and Materials:

- EFG™ Cone Material (epoxy Fiberglass-Kevlar)
- Nylas Frame (Nylon Fiberglass)
- Poly-MGS (Polypropylene-Mica Glass Sphere Composite)
- Maxed™ Amplifier Power supply
- REV TEC™ Tower Speaker Technology
- DSP-Integrated OEM Amplifiers
- DSP Black Box Radio with CANbus Control
- Wireless A-Link™ Send/Receive System

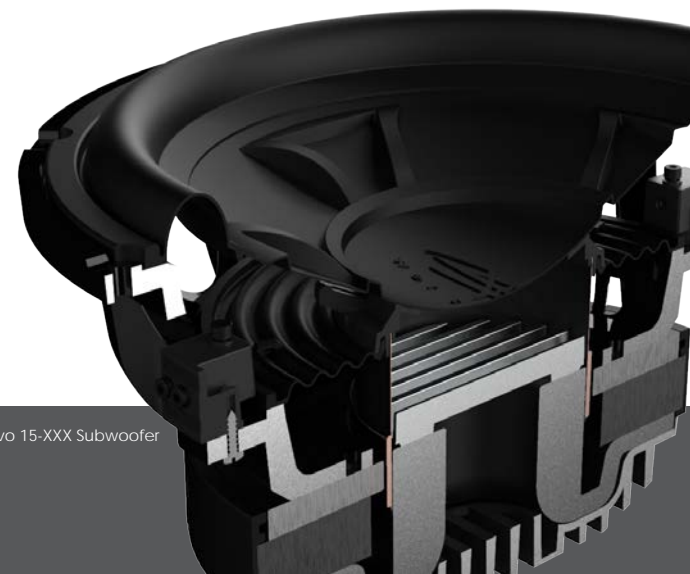

Revo 15-XXX Subwoofer

IN-HOUSE PRODUCT DEVELOPMENT

Wet Sounds has a full product development team in-house. Capabilities include Industrial Design, Engineering, CAD, 3D printing and Prototyping, Fabrication, Audio Testing and Voicing.

Manufacturing Capabilities

Speakers | Subwoofers | Amplifiers | Source Units

- Metal Stamping
- Metal Extrusion
- Thermo Forming
- Injection Molding
- Rotational Molding
- Precision Casting for Stainless Steel
- Die Casting for Aluminum, Electronics, Audio Components and much more

In-House Testing

- UV
 - Salt spray
 - Vibration
 - Drop testing
 - EMI
 - Environmental Temperatures:
 - Extreme heat
 - Extreme cold
- 3rd party independent testing also available

IN-HOUSE PRODUCT DEVELOPMENT

Innovation is the key to our success. By pursuing new technologies, materials, and unique engineering, we have developed many award-winning products. Wet Sounds has won multiple Innovation Engineering Awards from the Consumer Electronics Association & NMMA.

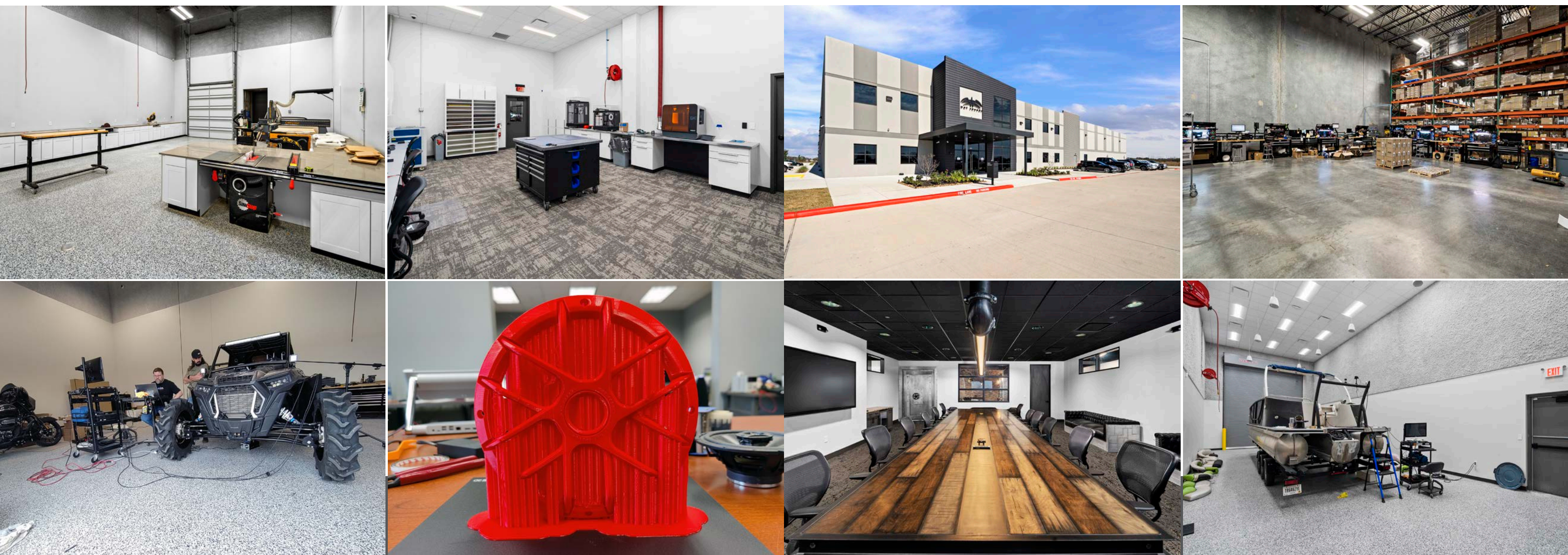

WS-BB-10 | AUDIO BLACK BOX

The WS-BB-10 is the heart of the Wet Sounds network system. Because this is the source unit along with all of the amplifier controls, we control the signal from its origin all the way to the speakers. This means, maximum performance at every listening level along with the highest level of protection to all audio components. This unit can be customized for each model and system configuration and can be updated using a Bluetooth® device or USB. WS-BB-10 is a AM/FM/ Weather Band Tuner. It includes Bluetooth® Streaming with full playback control, Sirius XM Ready, NEMA 2000, 10 Channel / 5 Zone, and Digital Signal processor for variable outputs.



INPUTS

- AM/FM/WB Tuner
- USB Input with MFI
- Analog auxiliary input for glovebox
- Auxiliary input for mOSI
- Data Remote Control input that supports two remotesx
- Software updates via USB or Bluetooth
- SiriusXM input
- SWC input - basic remote command input

OUTPUTS

- **5 zones** of analog low level audio output (4 volts RMS) - can be controlled independently or together
- **Fixed analog audio** output for RGB lighting or other accessories

WS-BB-10 | AUDIO BLACK BOX

Each output channel is routed through an advanced DSP chip that allows for extensive control over each speaker package. This DSP chip utilizes standard features like EQ, crossovers, time alignment, phase control as well as advanced features like bass augmentation algorithms, customizable dynamic compression, peak limiting for added system protection, and internal tone generation from external triggers. All of these features can be tailored for each model for every system configuration and since the DSP is located in one location, programming is much easier.

CANBUS COMMUNICATION

- ISO 11898-1:2003 - pending
- SAE J1939
- NMEA 2000

CONNECTIONS

All connections are either a sealed pigtail or a sealed chassis mounted connector

MOUNTING

Raised mounting feet for added moisture protection



WS-MC-1 | MARINE MEDIA CENTER

Wet Sounds Media Center (WS-MC-1) is an industry-leading, two-piece marine-grade, multi-zone source unit. This package includes two components: the MC-MD main display/control center and the MC-BB remote mounted processing unit. The MC-1 is personally customizable to store and control your favorite input sources, while also storing audio presets for 4 zones. Use the MC-1 to set multiple volume levels for a variety of lifestyle environments, then add custom labels to the presets for fingertip access while on the water.

WS-MC-1 | MARINE MEDIA CENTER

FEATURES INCLUDE:

- Adjustable Input Gain levels
- Water-resistant rotary control for IPX6 Intrusion protection (MC-MD)
- Conformal Coated PC Board for IPX5 Intrusion Protection (MC-BB)
- Optional MC-TR Transom Remote
- Fully-upgradeable Software & Firmware via USB Port
- Simple & Secure Pairing Bluetooth® Profile for Android™ & iOS
- Displays Album Art from Connected Devices
- Playlist & Folder Browsing via BT or USB Connection
- Auxiliary Input, USB Input, Bluetooth® Streaming Input, USB, Pandora, SiriusXM-Ready® (SXV300V1)
- Internal Power Amplifier: 4x50W, 2-Ohm Stable

- Marine-grade AM/FM/Weather Band RDS Radio digital tuner
- Bluetooth®, A2DP Only, AVRCP 1.3, APTX
- Optional 4 Zone RGB Controller (WS-4Z-RGB-BB Controller V2)

- Compatible with Transom/Auxiliary Remote WS-MC-TR



MC-BB

MC-MD



.75" D



7" W

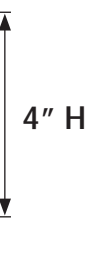

4" H



10" W

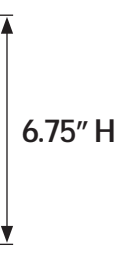

6.75" H





WS-MC-20 | 2-ZONE NMEA COMPATIBLE MEDIA RECEIVER

The WS-MC-20 Compact 2-Zone Media Receiver Source Unit with SiriusXM-Ready® is here. The WS-MC-20 provides a great solution for those who need to install a receiver in smaller and tighter spaces all while maintaining the ability to provide Wet Sounds unmatched sound quality. Enjoy AM/FM/Weather Band, Bluetooth® Audio, SiriusXM® (with SiriusXM Connect Tuner and Subscription Package, Sold Separately) and NMEA connectivity with optional interface accessory. Now, you can also connect your back-up camera to the MC-20 via the video input so you can always be aware of your surroundings.



WS-MC-20 | 2-ZONE NMEA COMPATIBLE MEDIA RECEIVER

FEATURES INCLUDE:

- AM/FM/Weather Band Tuner with RBDS
- Bluetooth® Streaming, Auxiliary, & USB Inputs
- SiriusXM-Ready™ (SiriusXM Connect Tuner and Subscription sold separately)
- Simple & Secure Bluetooth® Pairing for Android & iOS (A2DP/AVRCP 1.4)
- 3" Ultra Bright Full Color TFT Display – Displays Album Art via Compatible Devices
- Internal Power Amplifier 4x50W @ 2Ω Max Output
- Preamp Outputs X 3: Front, Rear & Switchable, Zone 2 or Subwoofer Output w/ Level Control
- Independent Volume Control for Secondary Zone – Full Range or Subwoofer w/ Selectable LP Crossover 60/80/100Hz. LP Crossover Slope Selectable at 12dB or 24dB per Octave
- Reverse Camera Video Input with Reverse Trigger
- NMEA 2000® Connectivity (WS-G2-NEMA-20 required)
- Day/Night Illumination & Dimming
- Accepts the Optional WS-G2-CTR Transom Remote & WS-G2-TR Transom Remote
- Optional Flush Mount Bezel



WS-MC-2 | MARINE MEDIA CENTER

Following up on the success of our MC-1, we've developed a unit that will work in any application; both off-road and on the water. The MC-2 Digital Media Receiver with 2.7" full-color display is designed to be a solution for installing a high-quality receiver in smaller and tighter space, while still maintaining Wet Sounds' unmatched sound quality and durability.



Power: Internal Power Amplifier
4x50W @ 2Ω



	MC-2
Screen Size	2.7" TFT Color Display
Internal Power	50W x 4 @2Ω
Bluetooth	Yes
Zone Control	Yes
Zone Options	Front/Rear w Fading
Tuner	AM/FM Weather Band w/ RDS
Browse	Playlist & Folder w/ Compatible Device
Illumination	Day/Night & Dimming
Hole Cut-Out	2.59"
Mounting Depth	5.94" w/ Grille

WS-MC-2 | MARINE MEDIA CENTER

FEATURES INCLUDE:

- Internal Power Amplifier 4x50W @ 2Ω Max Output
- 7-Band Equalization
- Adjustable Input Gains for all Inputs
- SiriusXM-Ready®
- Built-in Crossovers: HPF for Front & Rear, LPF for Zone 2
- Front & Rear Preamp Outputs with Fading Capability
- Simple & Secure Bluetooth® Pairing for Android & iOS (A2DP/AVRCP 1.4)
- Playlist & Folder Browsing via BT or USB Connection with Compatible Devices
- Front-Panel Mounted Independent Secondary-Zone Control – Full Range or Subwoofer
- 2.7" Full-Color TFT Display
- AM/FM/WB Digital Tuner
- Auxiliary Input (3.5mm)
- Day/Night Illumination & Dimming
- Bluetooth® Audio Streaming, Auxiliary, USB, Pandora Inputs & SiriusXM-Ready® (SXV300V1)
- USB Input with iPhone Connectivity, Charging and MP3 Capability
- Compatible with up to 3 Transom Remotes (MC-TR) with Optional MC-TR-EXT and MC-TR-Y



WS-MC-5 | AM/FM DIGITAL TUNER

Introducing the newest receiver to the Wet Sounds lineup, the WS-MC-5 AM/FM Bluetooth® receiver. Enjoy your favorite music with Bluetooth streaming, AM/FM Radio, or plug in your device via 3.5mm auxiliary input. The WS-MC-5 is the perfect introduction into Wet Sounds' media center product line, sharing the same compact design as the MC-2 which allows the MC-5 to be the perfect solution for any marine or powersports application.



WS-MC-5 | AM/FM DIGITAL TUNER

FEATURES INCLUDE:

- AM/FM Digital Tuner
- Bluetooth® Streaming, Auxillary Input
- 2.7" LCD Display
- 50W x 4 @ 2Ω Internal Amplifier
- Front & Rear Preamp Outputs w/ Fading Capability
- Front Panel Mounted Independent Secondary Zone Control - Full Range or Subwoofer
- Day/Night Illumination & Dimming
- Bluetooth® Pairing for Android & iOS

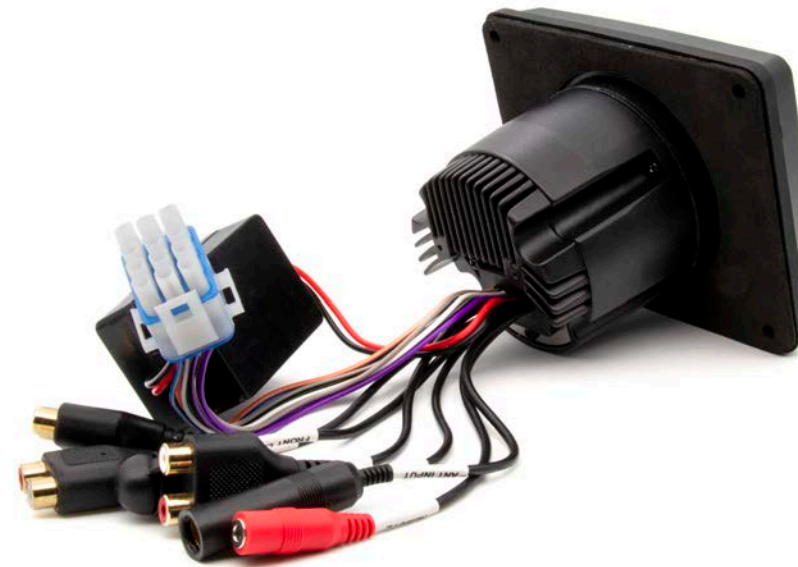

WS-G2-CTR | WIRED TRANSOM REMOTE

The new, compact Wet Sounds Transom Remotes work with the WS-BB-10, are compatible with the WS-MC-20, and allow remote control over the audio system. The WS-G2-CTR features a 3" color display, and allows full control of the WS-BB-10.



WS-G2-CTR

- FEATURES INCLUDE:
- Full Control of WS-BB-10
 - Color Display
 - 13 Pin DIN cable connection to WS-BB-10
 - IPX6 Rating - pending
 - Optional Flush mounting system
 - Extension cable included



WS-G2-TR | WIRED TRANSOM REMOTE

The WS-G2-TR was designed for installation in tighter spaces and can control Volume, Play/Pause, Source/Track Selection and Seek functions

WS-G2-TR

- FEATURES INCLUDE:
- Master Volume Control
 - Source Select
 - Song Selection
 - System Power
 - Seek Functions
 - 13 Pin DIN cable connection to WS-BB-10
 - IPX6 Rating - pending
 - Extension cable included



OE-CAN-TR | CANbus WIRED TRANSOM REMOTE

Using the Wet Sounds product development resources, a new CANbus transom remote can be designed and produced to meet Malibu's exact needs. The WS-TR-CAN would work with the WS-BB-10, by utilizing the CANbus communication network for control of the audio system. Designed for installation in tighter spaces, the WS-TR-CAN would control Volume, Play/Pause, Source/Track Selection and Seek functions.



- FEATURES INCLUDE:
- IPX7 Rated marine grade construction with 4 Pin Deutsch connection
 - Compact size; Easy mounting
 - For use with WS-MC-20
 - NMEA 2000 ready
 - NMEA to Deutsch adaptor cable included

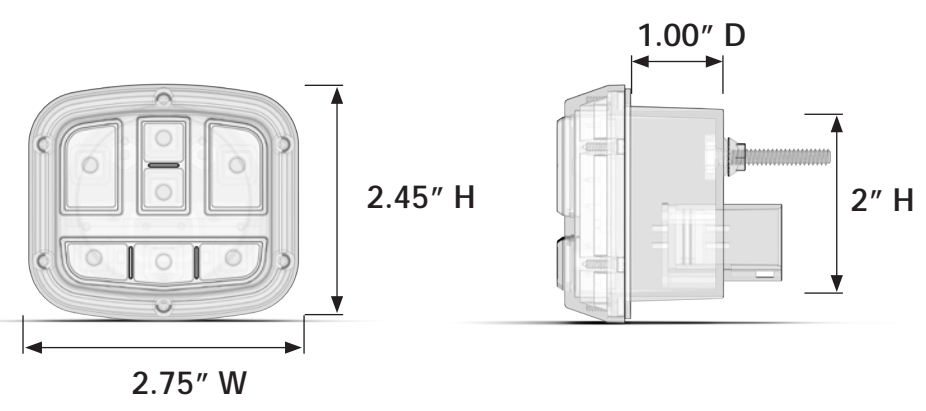

- Master Volume Control
- Source Select
- Song Selection
- System Power
- Seek Functions
- CAN communication to the WS-BB-10
- IPX7 Rating
- Easy to use button layout

WS-MC-TR-MINI | TRANSOM/AUXILLARY REMOTE

The MC-TR-MINI provides remote control of your audio system when combined with the Wet Sounds MC-1, MC-2, or MC-5 Media Centers. Remote functions include source change, volume control, track selection, play, and pause. Connect this compact, IPX7 rated marine remote with the included 25-foot 3.5mm AUX cable and mount it on any desired location. A simple software update and 3.5mm to DIN adaptor cable (MC-TR-MINI-ADP) is required for use with Wet Sounds MC-1 and MC-2 media centers.

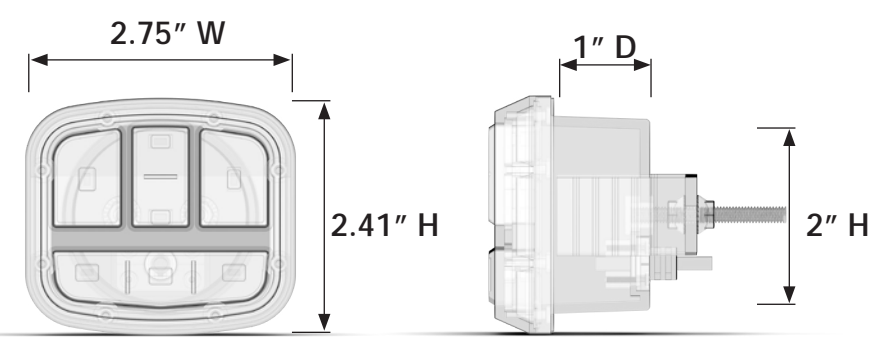
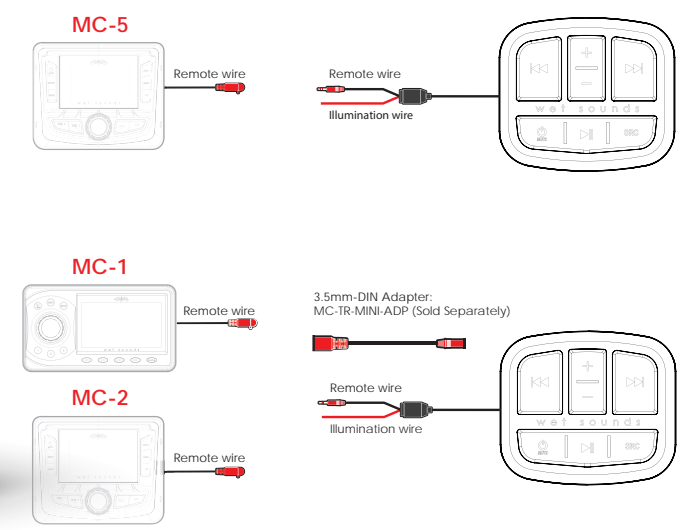

- MC-TR-MINI**
- IPX7 Certified marine grade construction
 - Compact size; Easy mounting



WS-MC-TR | TRANSOM/AUXILLARY REMOTE

With the Wet Sounds transom remote connected to your MC-1 marine media center or your MC-2, you can control your entertainment from the bow or from your swim deck. It connects to the MC-1/ MC-2 via the included 23-foot MC-TR EXT cable, and gives you the ability to adjust volume and choose audio sources when you are nowhere near the main display.

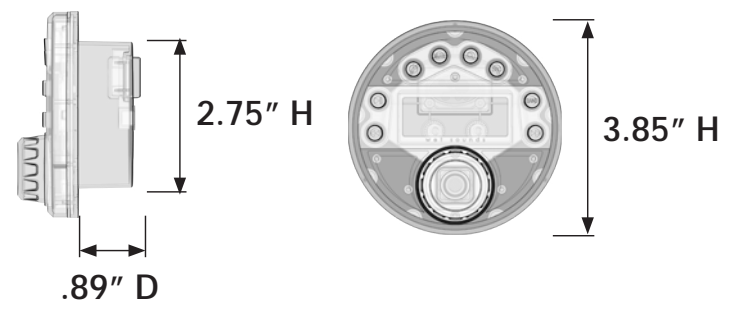

Optional add-ons:

- MC-TR Y-Cable: Connects up to 2 MC-TR units to an MC-1 or MC-2
- Additional MC-TR EXT 23-foot extension cable for extended mounting distance

WS-MC-TR | TRANSOM/AUXILLARY REMOTE

What makes this product great is allowing you the freedom to be at the front, back, or even outside the boat, while still maintaining the ability to easily access and change volume, source, song, etc. The MC-TR is usually mounted on the rear transom of the boat to allow control of the audio system without getting out of the water when swimming. Two MC-TR units can be used in conjunction (with optional MC-TR-Y cable), allowing access from both the front and rear of the boat.

FEATURES INCLUDE:

- Up to 50-foot distance from MC-BB (with additional MC-TR-EXT cable)
- Source, Playback, and Volume Controls
- Single-Line LCD Display
- Volume – Main level and each Zone individually
- Connects to the MC-BB via the supplied 23ft cable
- Allows control of radio, Bluetooth®, Pandora, and AUX

Source Unit Performance Matched Accessories

MC-1 MEDIA CENTER	WS-MC-TR	MC-MD 2	WS-4Z-RGB-BB	MC-UAP	MC-MD EXT	MC-MD Y
MC-20 2-ZONE MEDIA CENTER	AL-SR-V2	WS-G2-NMEA-20	WS-MC-20-FMK	WS-G2-CTR	WS-G2-TR	OE-CAN-TR
MC-2 MEDIA CENTER	WS-MC-TR	AL-SR-V2				
MC-5 AM/FM DIGITAL TUNER	WS-MC-TR	AL-SR-V2				
WS-BB-10	WS-G2-CTR	OE-CAN-TR				



WET SOUNDS BLUETOOTH® CONTROLLERS

With Wet Sounds Bluetooth® controllers, you now have 4 different options to add Bluetooth control to your system. Adjust the volume, as well as track playback in 4 different ways! Our entire line-up is sealed for both Marine and PowerSport use. Wet Sounds Bluetooth® controllers are the easiest and most cost-effective way to add Bluetooth® to any audio system!

WW-BT VC
Bluetooth®
Volume Control



WWX-DZ-BT
Dual-Zone
Bluetooth® Controller



- BT VC**
- The perfect add-on for the WS-420 SQ
 - iPhone, Android & Bluetooth® Device Ready
 - One knob controls – track, pause & volume
 - Flush in-dash or under-dash mounting
 - 3.5 mm output – Easy Add-on to any radio with AUX input

- DZ BT**
- Controls Volume, Track , Play/Pause & Aux Input
 - Controls Volume of 2 Zones
 - Zones Can Be Linked Together or Controlled Individually
 - Remote Output Turns an Amplifier On/Off
 - Mounts in 1-1/8" Opening
 - Back-Lit Button Illumination w/Seperate Illumination for Source Identification

WET SOUNDS BLUETOOTH® CONTROLLER

WW-BT UR
UNIVERSAL
Bluetooth® Receiver



WW-BT RS
Bluetooth®
Rocker Switch



- BT UR**
- Uses the controls on the BT device for Play/Pause, Track & Volume adjustment.
 - Power-saving feature - Turns off the amplifier if music is paused for more than 10-20 seconds.
 - Blue light indicates BT pairing status, Red light indicates amplifier status.
 - 3.5mm female connection for main output.

- BT RS**
- Controls Volume, Track , Pause & Aux Input
 - Mounts into a Standard Carling Switch opening
 - 3.5mm Connections for Main Output & Auxiliary Input
 - Volume Controls the BT & AUX
 - Remote Output Turns an Amplifier On/Off



REV 10/12 HD | TOWER SPEAKER

The Wet Sounds Revolution Series uses our proprietary REV TEC™ technology. Unlike conventional designs, REV TEC technology provides remarkable volume and clarity, along with incredible, full-range sound quality at long distances - both on and off axis. Our REV TEC design features enhanced mid-bass response at all volume levels, along with smooth frequency-response for amazing near-field and wide-range sound quality. Available in gloss black and gloss white with UV inhibitors.

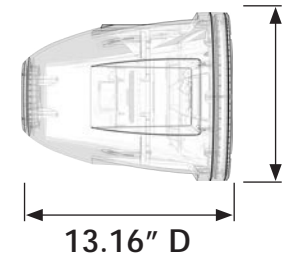
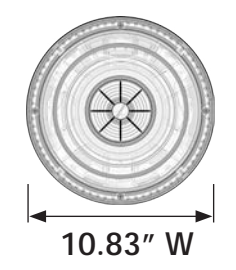

REV 10 HD
 POWER (W): 300/600 (RMS/Peak)
 IMPEDANCE: 4Ω
 FREQ. RESPONSE: 66Hz to 20 kHz
 SENSITIVITY: 90.9dB at 1W/Meter
 Hang Weight: 14.33 lbs each



REV 10/12 HD | TOWER SPEAKER

FEATURES INCLUDE:

- Rigid PHGS composite Cone
- HTPR Surround Suspension System
- High Output Horn Loaded Compression Driver
- Reinforced Nomex Aramid Spider
- Integrated Front & Rear RGB LED Rings
- Stainless Steel Hardware
- 3 Available Grille Options

Optional add-ons:

- Transparent Grilles
- 6-pin Connector

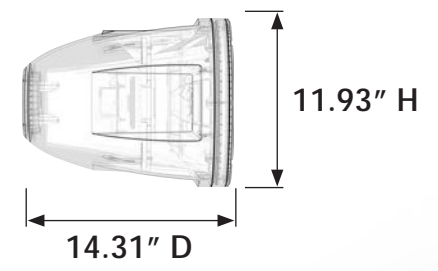
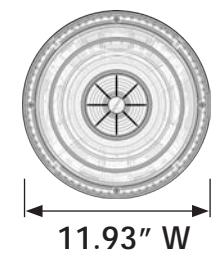

REV 12 HD
 POWER (W): 400/800 (RMS/Peak)
 IMPEDANCE: 4Ω
 FREQ. RESPONSE: 58Hz to 20 kHz
 SENSITIVITY: 91.0dB at 1W/Meter
 Hang Weight: 19.84 lbs each



REV 8/10 V2 | HLCD TOWER SPEAKER

Take your experience to the next level with the Revolution Series Tower Speakers from Wet Sounds. Enjoy the best full range sound quality on and off axis at long distances while riding behind your wake boat thanks to the high performance woofer using a kevlar-reinforced cone and polyurethane surround for extra strength. Powerful highs from the titanium horn loaded compression driver will provide crisp, sound clarity at high volume levels so you won't miss a beat.

FEATURES INCLUDE:

- Kevlar reinforced EFG™ cone woofers with polyurethane surround
- Pro-Axial™ Driver - Coaxially mounted Titanium Diaphragm High Output

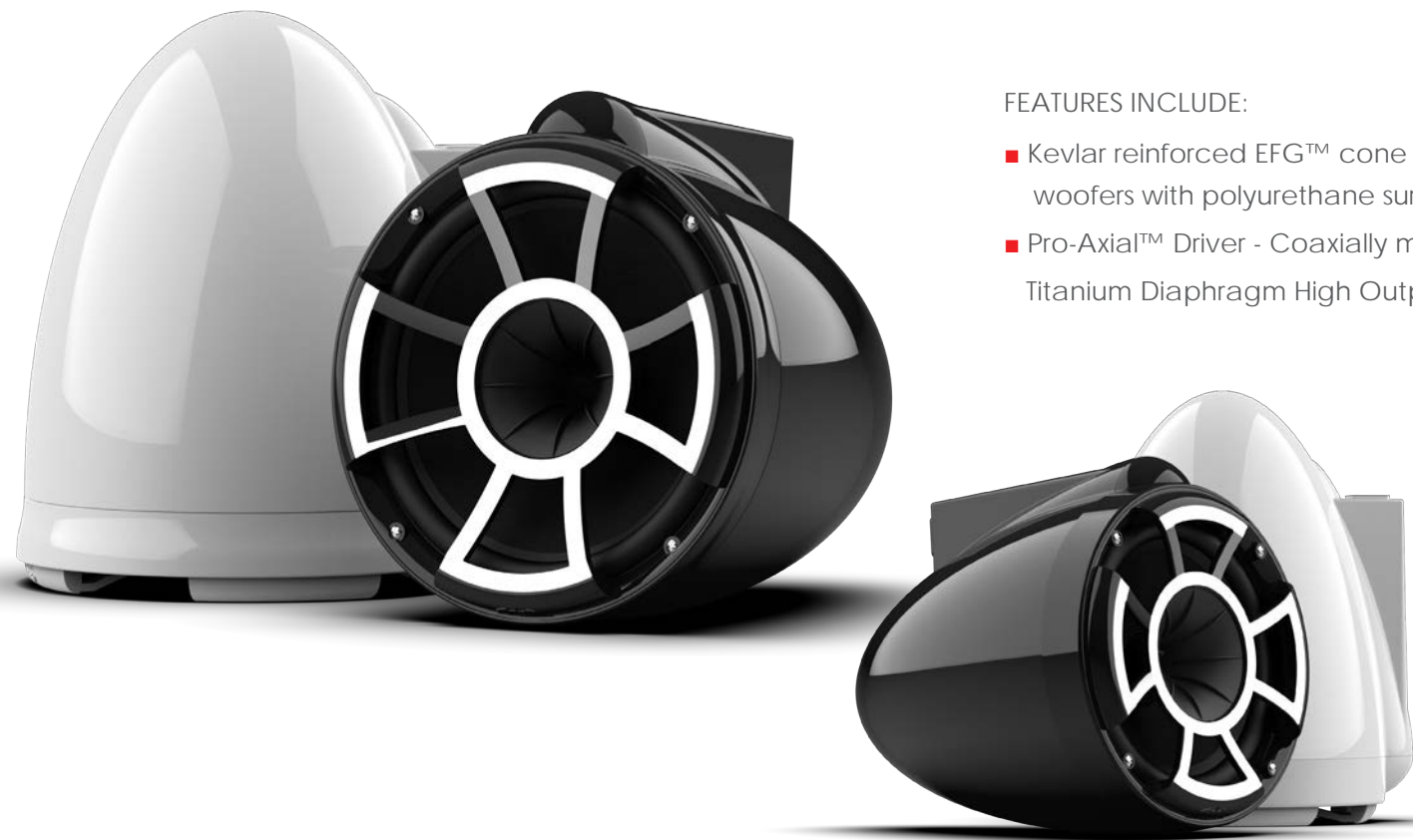

ICON 8 V2 | 8" COAXIAL TOWER SPEAKER

The ICON Series is an extreme-performance tower speaker designed for those craving a full, mid-bass sound and clean, detailed highs in a smaller enclosure. The ICON 8 utilizes an 8-inch continuous cone mid-bass driver, with a grille-mounted 1-inch titanium tweeter. Available in gloss black and gloss white pairs.

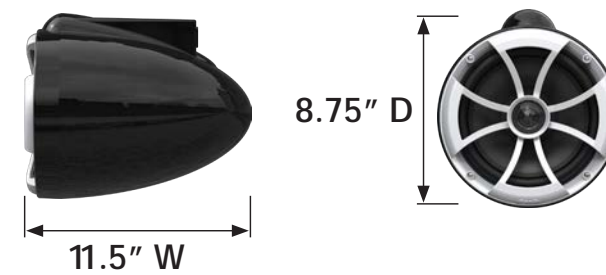

POWER (W): 150/300 (RMS/Peak)
 IMPEDANCE: 4Ω
 FREQ. RESPONSE: 20 Hz - 20 kHz
 SENSITIVITY: 92dB at 1W/Meter

Optional add-ons:

- RGB LED rings
- Transparent Grilles
- 6-pin Connector

REV 10
 POWER (W): 300/600 (RMS/Peak)
 IMPEDANCE: 4Ω
 FREQ. RESPONSE: 20 Hz - 20 kHz
 SENSITIVITY: 92dB at 1W/Meter

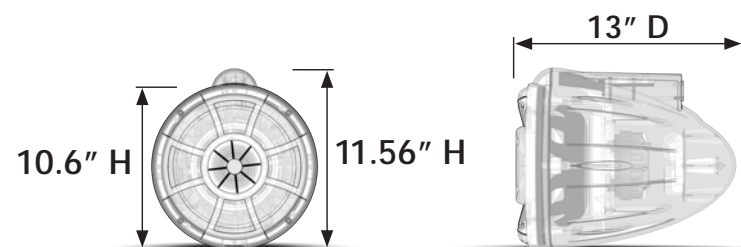

REV 8
 POWER (W): 200/400 (RMS/Peak)
 IMPEDANCE: 4Ω
 FREQ. RESPONSE: 20 Hz - 20 kHz
 SENSITIVITY: 92dB at 1W/Meter

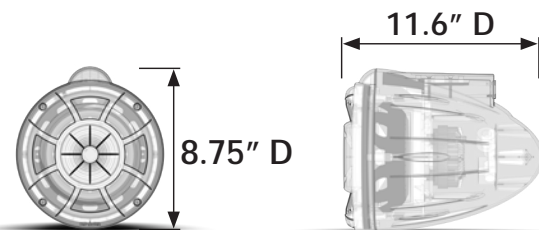

RECON 6 POD | PODS

The RECON 6 was specially designed for use with Wet Sounds' STX micro amplifiers. The RECON Pods come with clamps which allow for sturdy, tubular mounting on bars up to 2 inches in diameter and can also be configured for surface mounting. The RECON 6 PODs all come with multi-color RGBs. Available in black and white pairs, with 3 grille options.



RECON 6 POD | PODS

Wet Sound's RECON 6 POD-BG is tailor-made for adventure, both on the water and on land, thanks to the high impact 6.5" mid driver, a Conex spider and Santoprene™ surround. This black grille option was crafted as an option to better match your dream build, whether your tower speaker need is on a boat, SXS, ATV, or golf cart. The RECON 6 POD was specifically designed for low power applications and can even be used with power built into most source units/receivers. The lightweight Nylas frame is made from a combination of nylon and fiberglass. The injection-molded composite cone, aligned with the high output 1" titanium dome tweeter, deliver a supreme sound. The RECON 6 POD-BG comes complete with RGB back-lit tweeter, allowing for personalized accent lighting. It pairs nicely with Wet Sounds RGB Music Controller (RF-RGB-MC V2), which is sold separately.

- FEATURES INCLUDE: 
- Integrated 360-degree Swivel Clamp
 - Fits up to a 2" Round Bar
 - Flat Deck-mounting Flange
 - Adjustable Housing Ring to Mount Grille at Any Angle
 - 2-way Component-Style Coaxial with Aluminum Dome Tweeter
 - Injection-Molded Composite Cone with Santoprene Surround

RECON 6 POD-B/POD-W/POD-BG
 POWER (W): 60/120 (RMS/Peak)
 IMPEDANCE: 4Ω
 FREQ. RESPONSE: 40-20 Hz
 SENSITIVITY: 89dB at 1W/Meter
 DIAMETER: 6.8 inches with grille
 MOUNTING DEPTH: 2.6 inches

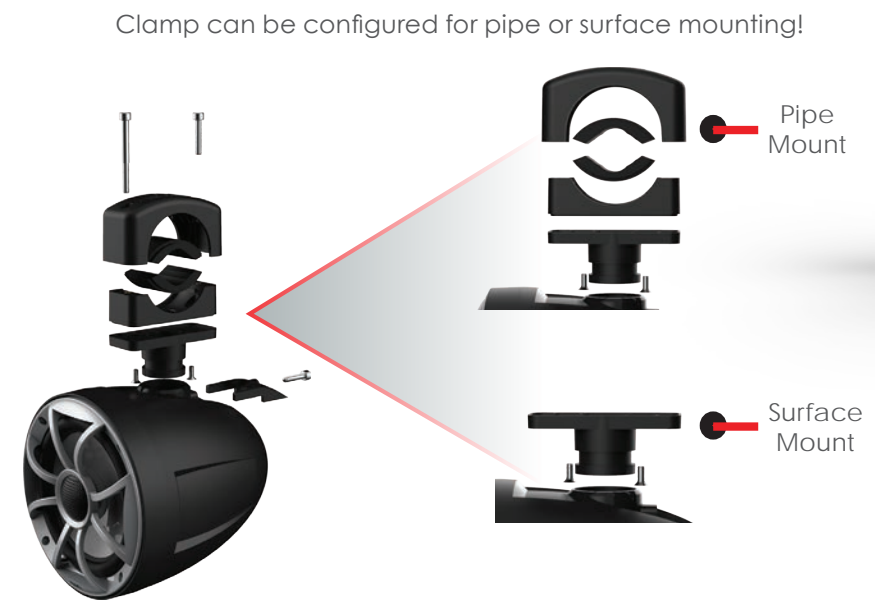
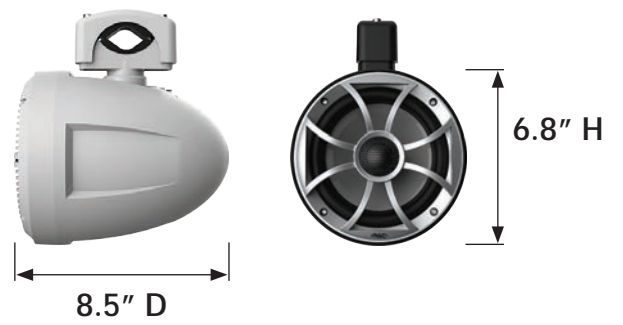

ZERO SERIES | COAXIAL SPEAKERS

The ZERO Series is a first of its kind innovation for Wet Sounds, taking the legendary REV tower speaker performance and reimagining it for optimal use in more confined spaces. The high output in small, sealed enclosures means ZERO Series allows for ZERO compromises. These speakers can also be used with or without a twist-lock grille, making them ideal for both custom and OEM replacement applications. The ZERO Series speakers and subwoofers utilize materials such as Nylas, a composite of nylon and fiberglass, providing improved stability and superior strength versus conventional speaker materials.

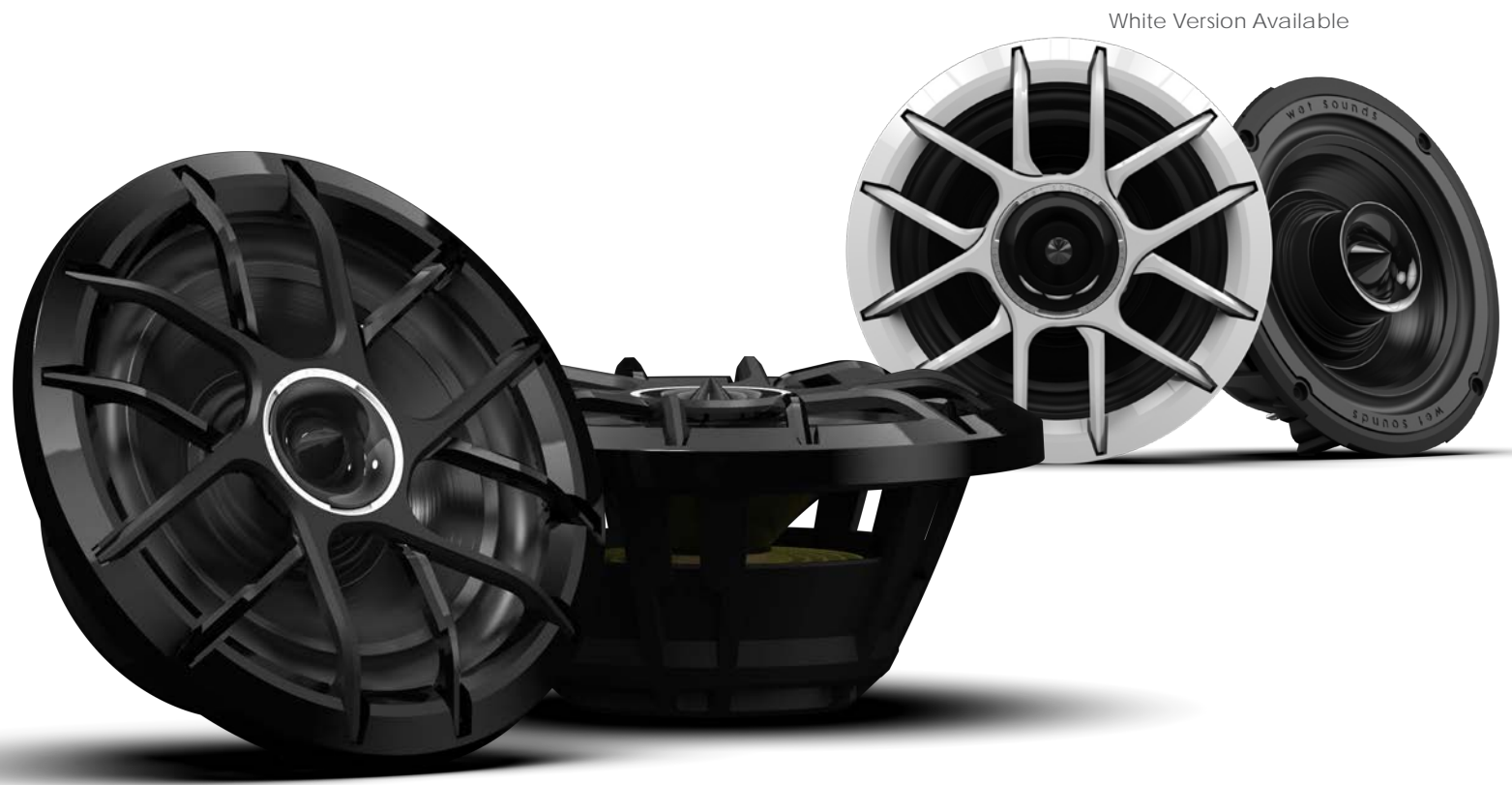

ZERO SERIES | COAXIAL SPEAKERS

NEW FOR 2024



Designed for that clean, low-profile look, the sleek XY Yacht Grilles install in a breeze with an easy twist lock system to fit flush with your boat's interior for a seamless, high-class style that fits any aesthetic. Constructed from aluminum with a durable powder coat finish to resist corrosion from the harsh marine environment.

- Currently only available in White
- All XY grilles feature a twist-lock installation (Adaptor Ring provided for use with the REVO Subwoofer)
- The ZERO Series™ 6 & 8 coaxial speakers will come pre-installed with XY grilles
- 10" & 12" Grille for use with: ZERO 10 & REVO 10 Subwoofers (ZERO 10 comes w/ XZ grille, so yacht grille needs to be purchased separately)

ZERO 6 POWER (W): 100/200 (RMS/Peak)
 IMPEDANCE: 4Ω
 FREQ. RESPONSE: 65Hz to 20kHz
 SENSITIVITY: 90dB at 1W/Meter



ZERO 8 POWER (W): 150/300 (RMS/Peak)
 IMPEDANCE: 4Ω
 FREQ. RESPONSE: 55Hz to 22kHz
 SENSITIVITY: 91.5dB at 1W/Meter



FEATURES INCLUDE:

- Twist-lock grille hides mounting hardware
- Incorporated motor heatsink
- Install with or without grille
- Oversized Neo motors for high power handling
- Horn-loaded tweeter
- Designed for outdoor performance

REVO V3 | COAXIAL SPEAKERS

The best-performing Wet Sounds coaxial speaker yet! The REVO series coaxial speakers are designed to provide superior sound quality with amazing mid-bass and clarity at high volume. Wet Sounds REVO series speakers feature a Conex Spider - impervious to water saturation and dry rot. REVO coaxial speakers also include RGB lighting for endless color options. Available in black and white pairs with 8 different grille options.

AVAILABLE WITH 8 DIFFERENT GRILLE OPTIONS

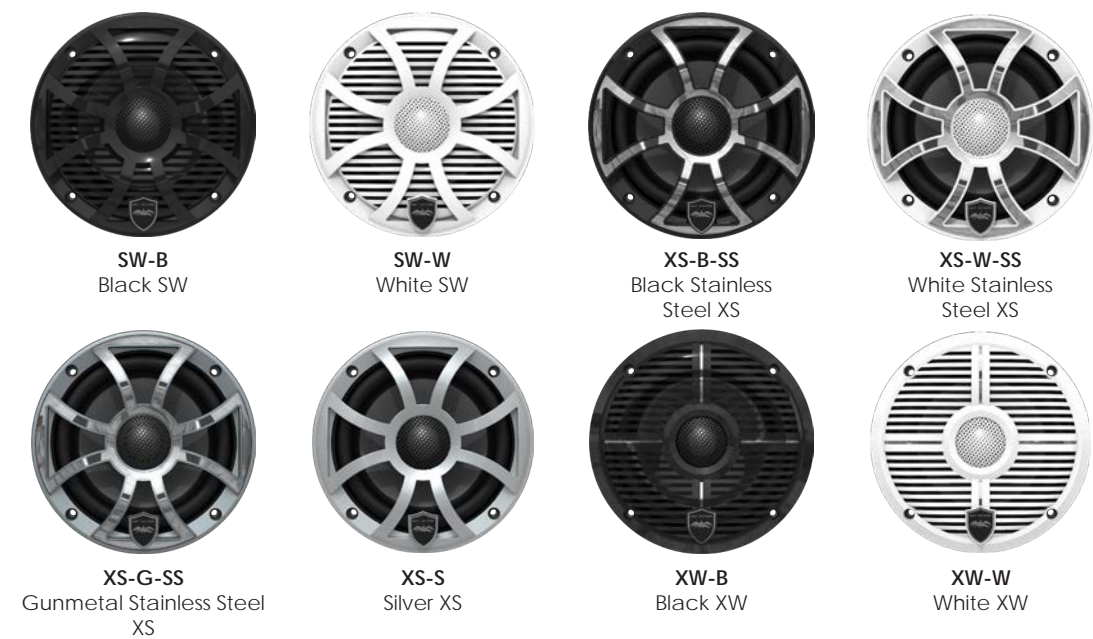

SW-B
Black SW

SW-W
White SW

XS-B-SS
Black Stainless Steel XS

XS-W-SS
White Stainless Steel XS

XS-G-SS
Gunmetal Stainless Steel XS

XS-S
Silver XS

XW-B
Black XW

XW-W
White XW

FEATURES INCLUDE:

- RGB LED Tweeter Glow Kit included - choose your own custom color options
- Conex Spider & Santoprene™ Surround
- Wet Sounds exclusive Nylas™, high stiffness composite frame available in 6.5" and 8"

REVO 6 V3
 POWER (W): 100/200 (RMS/Peak)
 IMPEDANCE: 4Ω
 FREQ. RESPONSE: 40 Hz - 22 kHz
 SENSITIVITY: 90dB at 1W/Meter



REVO 8 V3
 POWER (W): 150/300 (RMS/Peak)
 IMPEDANCE: 4Ω
 FREQ. RESPONSE: 35 Hz - 22 kHz
 SENSITIVITY: 92dB at 1W/Meter



Optional add-ons:

- Optional RGB Controller WWX-RGB-RS, RF-RGB-MC-V2
- Optional LED RINGS available

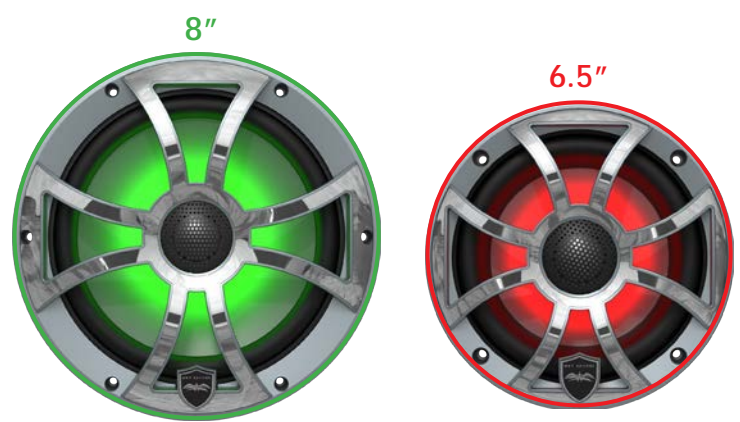

RECON | COAXIAL SPEAKERS

Wet Sounds presents the RECON Series - a line of high performance audio speakers. We offer multiple sizes from 5 1/4" - 8" including our RECON 6 Coaxial Pod tower speakers. If you're looking for high performance sound at an affordable price, then look no further! Sold in pairs.

RECON 6



RECON 6-S RGB RECON 6 XW-W RGB RECON 6-BG RGB

RECON 8



RECON 8-S RGB RECON 8 XW-W RGB RECON 8-BG RGB

RECON 6

POWER (W): 60/120 (RMS/Peak)
 IMPEDANCE: 4Ω
 FREQ. RESPONSE: 40-20 Hz
 SENSITIVITY: 89dB at 1W/Meter

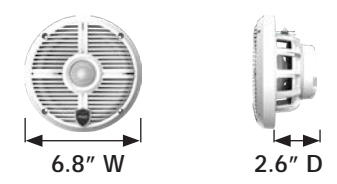

RECON 8

POWER (W): 70/140 (RMS/Peak)
 IMPEDANCE: 4Ω
 FREQ. RESPONSE: 40-20 Hz
 SENSITIVITY: 89dB at 1W/Meter

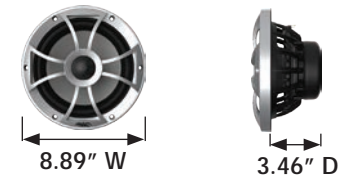

REV 6x9 | REV 5x7 | SURFACE MOUNT ENCLOSURE

The new REV 5x7 or REV6X9 feature a high output HLCD driver enclosed in a durable marine-grade rotomolded housing that is easily surface mountable making this a perfect addition to the under gunnel of most large boats giving you an amazing sound with a compact size! Available in a BLACK or WHITE Roto-Mold housing. Delivering amazing sound throughout your boat, ATV, Golf Cart or most any application! For under gunnel use, minimum 7" width is needed for placement.

Black Version:
REV 6X9 SM-W

White Version:
REV 6X9 SM-W



REV 5X7 SM-W



REV 6X9

POWER (W): 150/300 (RMS/Peak)
 IMPEDANCE: 4Ω
 FREQ. RESPONSE: 20 Hz - 20 kHz
 SENSITIVITY: 89dB at 1W/M

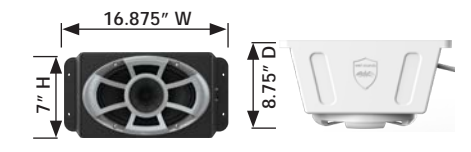

REV 5X7

POWER (W): 75/150 (RMS/Peak)
 IMPEDANCE: 4Ω
 FREQ. RESPONSE: 100 Hz - 20 kHz
 SENSITIVITY: 89dB at 1W/M

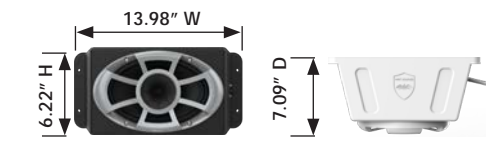

VENUE SERIES | SHALLOW MOUNT SPEAKERS

The Wet Sounds Venue Series Shallow Mount Ceiling Speakers are specifically designed and engineered for any shallow mount and or in-ceiling application that needs to withstand the demands of rigorous outdoor environments. The VS-SMC-65 delivers incredible sound by combining a composite mid-bass driver with a 1" PEI dome tweeter. Sold in Pairs. Available in White.

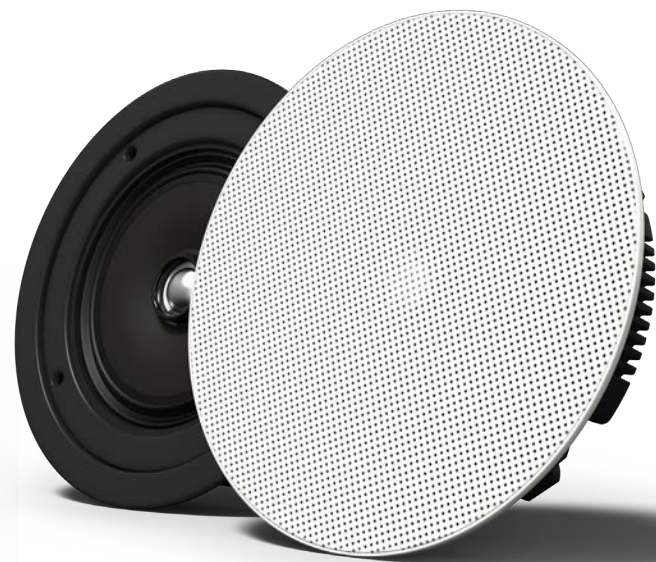

VS-SMC-65
 POWER: 50/100 (RMS/PEAK)
 FREQ. RESPONSE: 55 Hz - 20 kHz
 DIAMETER: 9.3"
 CUTOUT: 8.18"
 DEPTH: 2.12"
 IMPEDANCE: 8Ω

ZERO SERIES | SUBWOOFERS

Wet Sounds has developed a new subwoofer engineered specifically for delivering incredible bass performance in small, sealed enclosures. The parameters have been fine-tuned for "that sound" that everyone is looking for. It does all of this while still retaining a shallower mounting depth than our traditional REVO subwoofers.



ZERO 10
 POWER (W): 300/600 (RMS/Peak)
 IMPEDANCE: 4Ω
 FREQ. RESPONSE: 30Hz to 2kHz
 SENSITIVITY: 84.2dB at 1W/Meter

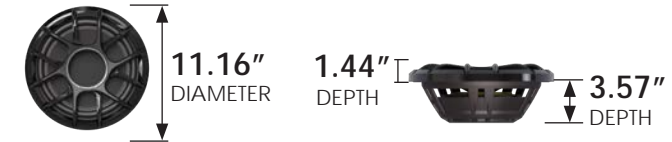

ZERO 12
 POWER (W): 400/800 (RMS/Peak)
 IMPEDANCE: 4Ω
 FREQ. RESPONSE: 25Hz to 2kHz
 SENSITIVITY: 85.9dB at 1W/Meter

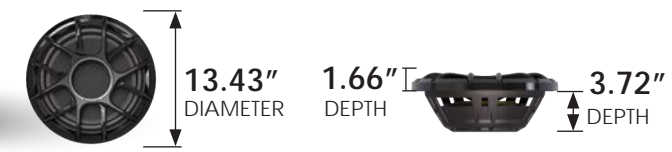

FEATURES INCLUDE:

- Shallow Mount Design
- Composite Injection Molded Frame
- Twist-Lock Grilles hides mounting hardware
- Install with or without grille
- Optimized for the demanding environments
- Black & white version available





REVO 12 XXX V4-B | 12" SPL MARINE SUBWOOFER

The REVO 12-XXX is the only SPL 12" marine-grade SPL in the world. Featuring a powder-coated, cast aluminum frame, with our blend of polypropylene/carbon fiber/glass fiber cone, coupled with a the massive magnetic system, high-roll Santoprene™ rubber surround, and a 4" dual voice coil. The 12-XXX also features gold-plated binding posts, an integrated, multi-part cooling system with a "T" yoke heat sink and pole-piece venting; ensuring high power and low voice coil temperatures for maximum reliability.

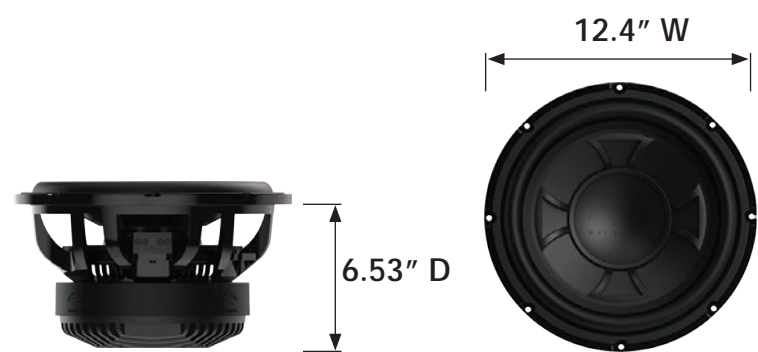

REVO 12-XXX SUBWOOFER

POWER (W): 1200/2400 (RMS/Peak)
 IMPEDANCE: Dual 2Ω
 FREQ. RESPONSE: 40 Hz
 SENSITIVITY: 88dB at 1W/Meter
 MOUNTING DEPTH: 6.53 inches
 WEIGHT: 33.4 lbs

REVO 15 XXX V4-B | 15" SPL MARINE SUBWOOFER

The REVO 15-XXX is the first purpose-built 15" marine-grade SPL subwoofer in the world. Advanced acoustic engineering and a composite cone make the REVO 15-XXX the subwoofer of choice for those wanting extreme bass. Ground-up design using CAD and Element Analysis gives you a woofer built for extreme use. Weighing in at over 70 pounds, the REVO 15-XXX not only gives you killer bass, but also some additional ballast! Features include a powder-coated, cast aluminum frame, our blended polypropylene/carbon fiber/glass fiber cone coupled to a the massive magnetic system, a high-roll Santoprene™ surround, and a 5" dual voice coil. Additionally, the 15-XXX features gold-plated binding posts, an integrated, multi-part cooling system with a "T" yoke heat sink and pole-piece venting; ensuring high power and low voice coil temperatures for maximum reliability.

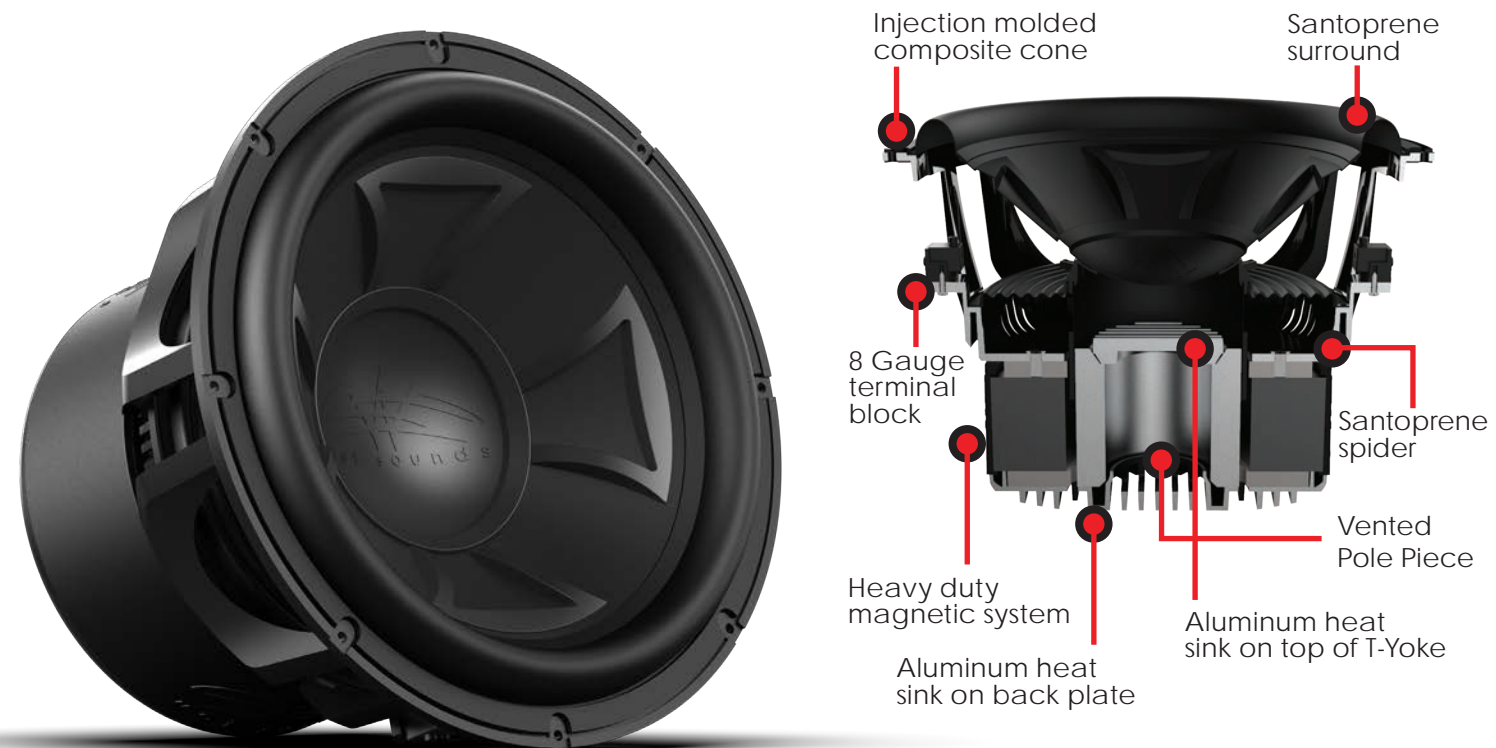

REVO 15-XXX SUBWOOFER

POWER (W): 2000/4000 (RMS/Peak)
 IMPEDANCE: Dual 2Ω
 FREQ. RESPONSE: 35 Hz
 SENSITIVITY: 88dB at 1W/Meter
 MOUNTING DEPTH: 10.5 inches
 WEIGHT: 71 lbs

REVO | SUBWOOFER FA/HP

For a complete audio experience, you cannot forget about bass! We have created what we believe to be the best marine-grade subwoofer on the market. The REVO Series subwoofers utilize Wet Sounds' exclusive Santoprene™ spider to eliminate any saturation or dry rot, making them the perfect choice for your marine application. Available in 8", 10", and 12" options.



REVO 8 SUBWOOFER
 REVO 8 FA S4-B
 FA S4 8 inch Free Air Marine Subwoofer
POWER (W): 200/400 (RMS/Peak)
IMPEDANCE: 4Ω
FREQ. RESPONSE: 20-500 Hz
SENSITIVITY: 88dB at 1W/Meter
DIAMETER: 8.89 inches with grille
MOUNTING DEPTH: 4.0 inches

REVO 10 FA SUBWOOFER
 REVO 10 FA S4-B V2
 S2/S4 10 inch Free Air Marine Subwoofer
POWER (W): 300/600 (RMS/Peak)
IMPEDANCE: 2Ω or 4Ω
FREQ. RESPONSE: 20-500 Hz
SENSITIVITY: 88dB at 1W/Meter
DIAMETER: 11.02 inches with grille
MOUNTING DEPTH: 4.72 inches

REVO 10 HP SUBWOOFER
 REVO 10 HP S4-B V2
 S4 10 inch **HIGH POWER** Marine Subwoofer
POWER (W): 400/800 (RMS/Peak)
IMPEDANCE: 4Ω
FREQ. RESPONSE: 20-500 Hz
SENSITIVITY: 88dB at 1W/Meter
DIAMETER: 11.02 inches with grille
MOUNTING DEPTH: 4.72 inches

Optional add-ons:
 ■ Optional LED Rings in sizes 8", 10", 12" subs



AVAILABLE WITH 8 DIFFERENT GRILLE OPTIONS



SW-B Black SW
SW-W White SW
XS-B-SS Black Stainless Steel XS
XS-W-SS White Stainless Steel XS
XS-G-SS Gunmetal Stainless Steel XS
XS-S Silver XS
XW-B Black XW
XW-W White XW

REVO 12 HP SUBWOOFER
 REVO 12 HP S4-B V2
 S4 12" **HIGH POWER** Marine Subwoofer
POWER (W): 500/1000 (RMS/Peak)
IMPEDANCE: 4Ω
FREQ. RESPONSE: 20-400 Hz
SENSITIVITY: 88dB at 1W/Meter
DIAMETER: 12.6 inches with grille
MOUNTING DEPTH: 4.92 inches

REVO 12 FA SUBWOOFER
 REVO 12 FA S4-B V2
 S2/S4 12" **FREE AIR** Marine Subwoofer
POWER (W): 400/800 (RMS/Peak)
IMPEDANCE: 2Ω or 4Ω
FREQ. RESPONSE: 20-400 Hz
SENSITIVITY: 88dB at 1W/Meter
DIAMETER: 12.6 inches with grille
MOUNTING DEPTH: 4.92 inches





RECON | 10" FREE AIR SUBWOOFERS

Introducing the RECON 10-inch subwoofer. The RECON 10 is optimized for infinite baffle/free air applications and designed to achieve maximum performance without requiring a tuned enclosure. Perfect for mounting under a seat and utilizing the cargo area as its enclosure. The RECON subwoofer utilize a Nylas composite frame, with an injection-molded composite cone and the Wet Sounds' signature Santoprene™ Spider. Bass made simple. Available with a silver or black RECON Grille or a white XW Grille to match any application.

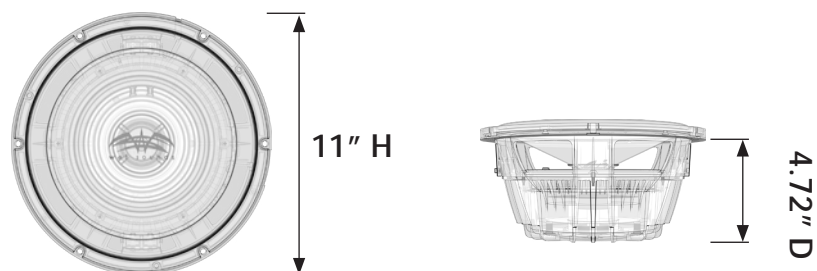

RECON 10
 POWER (W): 200/400 (RMS/Peak)
 IMPEDANCE: 4Ω
 FREQ. RESPONSE: 40-20 Hz
 SENSITIVITY: 89dB at 1W/Meter

* RGB Grille Sub Kit not compatible with RECON sub grilles

Optional add-ons:

- Optional 10" Subwoofer LED Rings available

REVO 12 PSE | 12 PASSIVE SUBWOOFER ENCLOSURE

Time to take bass to the next level with the new Revo 12 PSE. Utilizing our Revo 12 HP Subwoofer and 12" Revo Passive Radiator, this enclosure operates on the same principle as a ported enclosure while remaining sealed. The compact rotomolded enclosure comes pre-wired with weather proof speaker and RGB connections (Sub RGB kit sold separately). Installation and removal is simple with the quick-release mounts, The enclosure can also be mounted in any number of positions to meet any application.



Available with 8 different grille options.

Optional add-ons:

- Optional RGB Grille Sub Kit

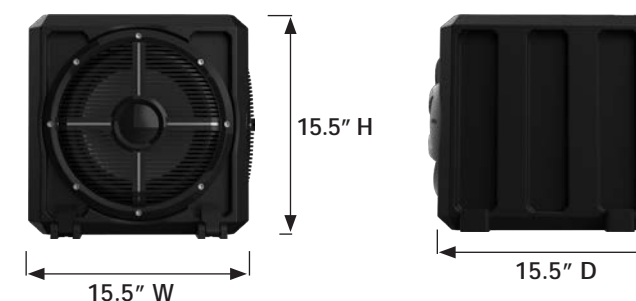

REVO 12 PSE
 POWER (W): 500w - 1000w
 IMPEDANCE: 4Ω
 FREQ. RESPONSE: 20Hz to 400Hz

STEALTH | XT POWERSPORT SOUNDBAR

The Stealth Series soundbars are designed to give every ATV, UTV, Golf Cart, Boat, and vehicle in your garage the ability to ride with a loud, live, and clear high performance audio solution.



REMOTE INCLUDED

STEALTH XT 6
 4 marine-rated 3" full range drivers
 2 marine-rated 1" tweeters
WEIGHT: 12 lbs

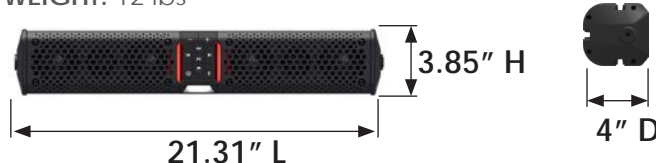

STEALTH XT 8
 6 marine-rated 3" full range drivers
 2 marine-rated 1" tweeters
WEIGHT: 15.2 lbs

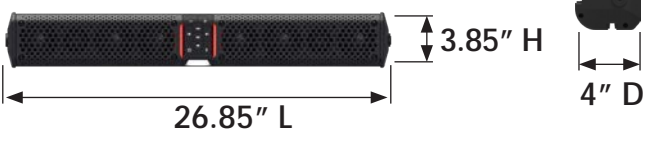

STEALTH XT 12
 8 marine-rated 3" full range drivers
 4 marine-rated 3/4" tweeters
WEIGHT: 18.6 lbs

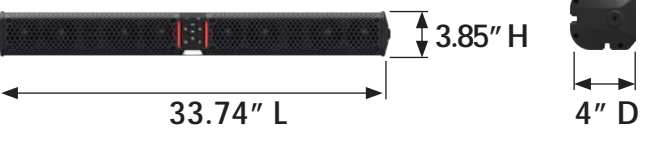

SPECIFICATIONS:
 600W Class D Amplifier
FREQ. RESPONSE: 40 Hz - 20 kHz
Max Current Draw: 15A
Operating Voltage: 10V-16V
IP Rated: IP67

Universal Mounting

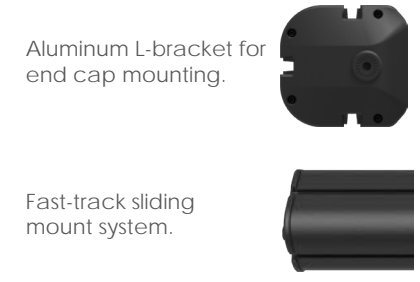

STEALTH | XT POWERSPORT SOUNDBAR



■ Only offered in black

FEATURES INCLUDE:

- Weatherproof rated for all outdoor marine and powersports applications
- Advanced DSP-controlled Class-D amplifier delivering clear sound, improved mid-bass and low-end bass response
- Built-in *Bluetooth*® connectivity with source control
- Sync multiple XT soundbars to share audio
- Backlit control panel & RGB accent lights with 12 color mode
- Integrated LED dome light
- Complete power/ground wire harness with in-line 20A fuse
- 3.5 AUX Input for a wired connection
- 3.5mm line output (2V) to connect an additional external amplifier and speakers.
- IP67 rated RF wireless remote
- Universal L-brackets and spacers with hardware included
- Wet Sounds patented Fast Track sliding mount system



STEALTH | ACTIVE SUBWOOFER ENCLOSURES

Tough and durable, the molded Polyethylene housings of the STEALTH AS Subs are designed to withstand any harsh environment, while providing superior low-bass output. The built-in Class D amp is sealed against moisture and dirt intrusion for extra protection and against the elements. All STEALTH AS series subwoofers have been designed with simple connections, for plug & play installation. The AS Subwoofer series are the perfect match for Wet Sounds STEALTH Ultra HD Soundbars, or any other application where you need to add bass. The STEALTH AS subwoofers can be added to any stereo - not just a Stealth Ultra HD Soundbar. Perfect for Jeeps and SUVs.

STEALTH AS-10

STEALTH AS-8

STEALTH AS-6



STEALTH AS-10
 POWER: 500/1000 (RMS/PEAK)
 FREQ. RESPONSE: 20 Hz - 250 kHz
 DIMENSIONS: 14.75"L x 12.75"H x 11.5"D
 BATT. VOLT RANGE: 10.5 - 16 VDC

STEALTH AS-8
 POWER: 350/700 (RMS/PEAK)
 FREQ. RESPONSE: 20 Hz - 250 kHz
 DIMENSIONS: 9.5"L x 10"H x 10.75"D
 BATT. VOLT RANGE: 10.5 - 16 VDC

STEALTH AS-6
 POWER: 250/500 (RMS/PEAK)
 FREQ. RESPONSE: 20 Hz - 250 kHz
 DIMENSIONS: 8.75"L x 8.5"H x 9.25"D
 BATT. VOLT RANGE: 10.5 - 16 VDC

FEATURES INCLUDE:

- Remote volume control with 18 foot cable included
- Hardware included

HTM | FULL RANGE CLASS-D AMPLIFIERS

Introducing the Wet Sounds HTM Series Amplifiers, the ultimate solution for extreme audio applications. Designed with precision and engineered for performance, HTM is equipped with Class-D power supplies, ensuring superior efficiency and extreme power output packed into a compact and sleek chassis. This amplifier is built to handle the most demanding environments, providing unparalleled reliability and robust performance.

NEW FOR 2024



Available Models **HTM-1** **HTM-8**

Features

- Full Range Audio Capability
- Selectable X-Over - High-Pass / Low-Pass / Full Range
- Removeable Power/SPKR Connectors
- Blue LED Back-Lit Badge on with Power
- Reduced height from previous HTX models
- Badging can be Mounted Horizontal or Vertical
- Optional Mounting Feet for Raising Amp from Mounting Surface

Tech Spec.	HTM-1
Amp Channels	1
Mono @ 4 Ohms	500W x 1
Mono @ 2 Ohms	800W x 1
Mono @ 1 Ohm	1200W x 1
X-Over Range	50 Hz - 500 Hz
S/N (Aveq-MAX Output)	105 dB
Freq. Response $\pm 3dB$	20 Hz - 20 kHz
Input Sensitivity	350 mVrms - 6 Vrms
Sub Sonic	10 Hz - 55 Hz
Dimensions (LxWxH)	9.62 x 2.35 x 5.80

Tech Spec.	HTM-8
Amp Channels	8
Stereo @ 4 Ohms	85W x 8
Stereo @ 2 Ohms	150W x 8
Bridged @ 4 Ohm	300W x 4
X-Over Range	50 Hz - 500 Hz
S/N (Aveq-MAX Output)	95 dB
Freq. Response $\pm 3dB$	20 Hz - 20 kHz
Input Sensitivity	350 mVrms - 6 Vrms
Sub Sonic (Ch. 7/8)	10 Hz - 55 Hz
Dimensions (LxWxH)	12.77 x 2.35 x 5.80

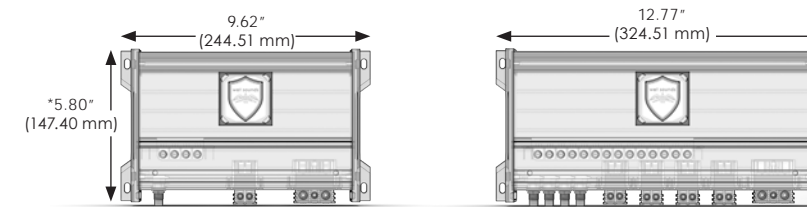

Full Range Capability!



IP5 Rated
 Sealed to keep music playing, and water out!



SINISTER SDX | AMPLIFIERS

The Sinister range of amplifiers are the highest-power marine amplifiers on the market, utilizing Wet Sounds-exclusive MAXED™ Class D Power Supplies, internal rectifier outputs and 4-layer circuit boards. What this means to you: uncompromised performance, outstanding sound quality, less current draw, less strain on your electrical system, and less heat generated so that you can play all day.

SDX 2



SDX 4



SDX 6



SDX 2500



Recommended for use with the REVO XXX series subwoofers

SINISTER-SDX2
2-Channel Amp
400 W x 2 @ 4Ω RMS
620 W x 2 @ 2Ω RMS
1250 W x 1 @ 4Ω RMS

14.5" x 10.25" x 3.0"

SINISTER-SDX4
4-Channel Amp
185 W x 4 @ 4Ω RMS
340 W x 4 @ 2Ω RMS
685 W x 2 @ 4Ω RMS

14.5" x 10.25" x 3.0"

SINISTER-SDX6
6-Channel Amp
185 W x 6 @ 4Ω RMS
290 W x 6 @ 2Ω RMS
585 W x 3 @ 4Ω RMS

14.5" x 10.25" x 3.0"

SINISTER-SDX2500
Monoblock Class D Subwoofer Amp
1000 W x 1 @ 4Ω RMS
1700 W x 1 @ 2Ω RMS
2500 W x 1 @ 1Ω RMS

22.125" x 10.25" x 3.0"

SYN-DX | AMPLIFIERS

Wet Sounds SYN-DX Series Marine Amplifiers are designed to be the amplifier of choice for every high-end marine audio system. SYN-DX amplifiers use advanced circuitry, high-quality components, oversized outputs, and efficient, Class D Power Supplies.

SYN-DX 2



SYN-DX 2.3 HP



SYN-DX 4



SYN-DX 6



SYN-DX2
2-Channel Amp
200 W x 2 @ 4Ω RMS
375 W x 2 @ 2Ω RMS
750 W x 1 @ 4Ω RMS

12.21" x 8.27" x 3.08"

SYN-DX2.3
HP 2-Channel Amp
300 W x 2 @ 4Ω RMS
600 W x 2 @ 2Ω RMS
1200 W x 1 @ 4Ω RMS

14.63" x 8.27" x 3.08"

SYN-DX4
4-Channel Amp
125 W x 4 @ 4Ω RMS
200 W x 4 @ 2Ω RMS
400 W x 2 @ 4Ω RMS

10.63" x 8.27" x 3.08"

SYN-DX 6
6-Channel Amp
Ch 1-4 125 W x 4 @ 4Ω RMS
200 W x 4 @ 2Ω RMS
400 W x 2 @ 4Ω RMS

Ch 5-6 150 W x 2 @ 4Ω RMS
300 W x 2 @ 2Ω RMS
600 W x 1 @ 4Ω RMS
14.57" x 8.27" x 3.08"

HYDRO-TECH™ X (HTX) | AMPLIFIERS

Wet Sounds Hydro-Tech™ X (HTX) Series of Marine Amplifiers are designed to be a complete solution for every marine application. HTX amplifiers use superior-performance circuitry and utilize Class D Power Supplies. These amplifiers have extreme power output, thermal overload protection, and flexible crossovers - all packed inside a small chassis. HTX Amplifiers are a well-balanced match for all of Wet Sounds™ products.

HTX-1
Monoblock Class D Subwoofer Amp



HTX-2
2-Channel Amp



HTX-4
4-Channel Amp



HTX-6
6-Channel Amp



HTX-1
Monoblock Class D Subwoofer Amp
330 W x 1 @ 4Ω RMS
650 W x 1 @ 2Ω RMS

10.125" x 7.375" x 3.0"

HTX-2
2-Channel Amp
150 W x 2 @ 4Ω RMS
300 W x 2 @ 2Ω RMS
600 W x 1 @ 4Ω RMS

10.125" x 7.375" x 3.0"

HTX-4
4-Channel Amp
100 W x 4 @ 4Ω RMS
150 W x 4 @ 2Ω RMS
300 W x 2 @ 4Ω RMS

10.125" x 7.375" x 3.0"

HTX-6
6-Channel Amp
100 W x 6 @ 4Ω RMS
150 W x 6 @ 2Ω RMS
300 W x 3 @ 4Ω RMS

13.75" x 7.375" x 3.0"

STEALTH | STX MICRO COMPACT CHASSIS AMPLIFIERS

The STX Micro-1 and STX Micro-4 are the latest in micro amps, designed for the Power Sports enthusiast or any application where space is limited. These small yet powerful amplifiers are designed with a completely sealed, die cast aluminum chassis for maximum protection against water and dirt intrusion. Both STX models are outfitted with 3.5mm signal-input connections, and work seamlessly with our Bluetooth controllers, or via direct connection to most smartphones' headphone jack.

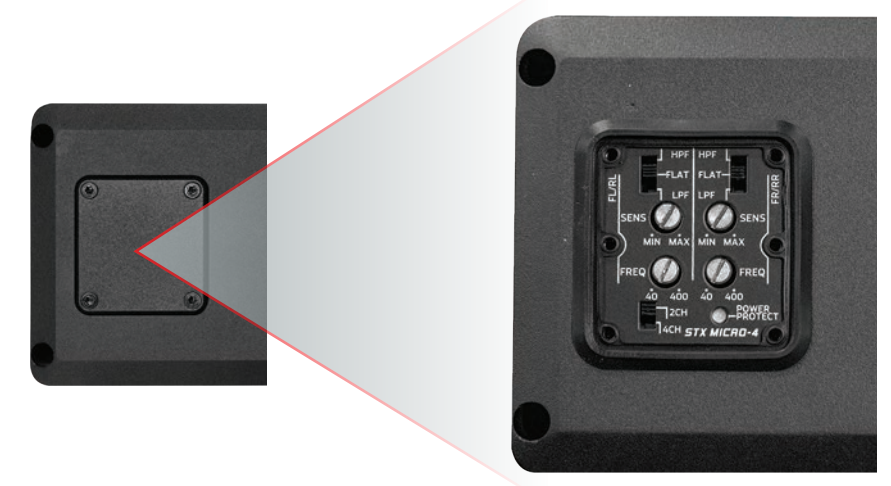

Gain and X-Over Controls

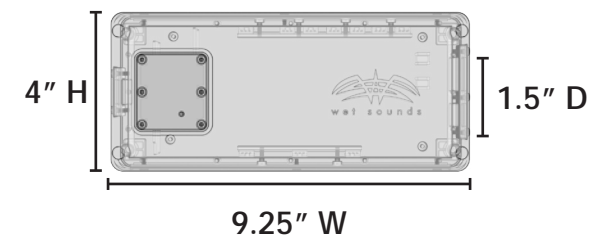

STX MICRO-1
Monoblock Class D Subwoofer Amp.
250W x 1 @ 4Ω RMS
420W x 1 @ 2Ω RMS
600W x 1 @ 1Ω RMS

STX MICRO-4
4 Channel Full-Range Class D Amp.
80W x 4 @ 4Ω RMS
130W x 4 @ 2Ω RMS
280W x 2 @ 4Ω RMS

OEM AMPLIFIERS | AMPLIFIERS

These amplifiers have been completely designed around the capabilities of the WS-BB-10 and the needs of the Network System. With the controls residing in the black box, these amplifiers can focus on their primary purpose - making power. This also allows us to use a new technology in amplifier design that results in smaller overall footprints, lower operating temperatures and additional durability. Cost savings on amplifiers allows the opportunity to produce an advanced black box superior to any offering ever seen in the industry.



Models Available	Power	IP Rating	Dimensions
6 Channel	150x6	IPX5	7.51" H x 5.43" W x 2.61" D
6 Channel	75x6	IPX5	6.77" H x 4.93" W x 2.61" D
4 Channel	75x4	IPX5	5.60" H x 4.70" W x 2.61" D
2 Channel	300x2	IPX5	6" H x 5.43" W x 2.61" D
Monoblock	1200x1	IPX5	6.31" H x 5.43" W x 2.61" D

- OE-AMP-150x6
- OE-AMP-75x6
- OE-AMP-75x4
- OE-AMP-300x2
- OE-AMP-1200x1

AMP BOARDS | TURN-KEY AMPLIFIER BOARDS

Offering an OEM turn-key solution in multiple amplifier configurations to meet your system requirements, complete with our OEM Amplifiers, WS-BB-10 Black Box, MRBF Fuse Box and all necessary harnessing to make our amp boards the perfect plug-n-play solution. The assembly will come pre-loaded with model specific tuning for your audio system, reducing installation time on the line, and insuring accurate system configurations.

Features

- Complete Plug-N-Play Ready
- All Necessary Harnesses & Hardware Included
- Available in any Amplifier Configuration
- Pre-Loaded DSP Tune for your System

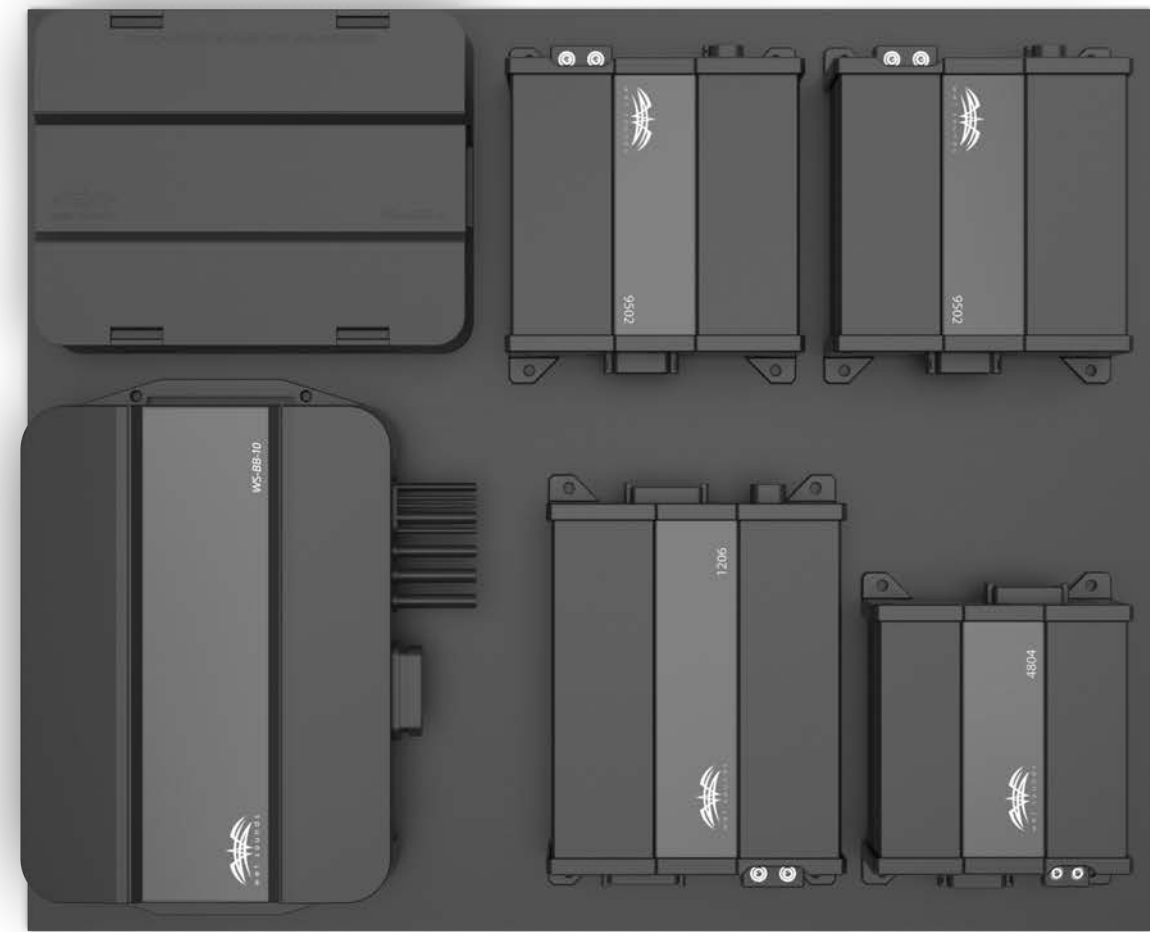

ZERO ENC | Roto-Mold Enclosures for Zero Subs

Innovation at its core, the **ZERO SUB ENC** boasts a rugged roto-mold design, engineered to withstand the beat of your favorite tunes. ZERO enclosures can be mounted in multiple orientations thanks to its versatile design. Easily connect multiple enclosures with the included side insert for even more bass, so you can use one, or use multiple, the choice is yours. The rugged design also provides structural support for the sub woofer to keep your tunes sounding their best.

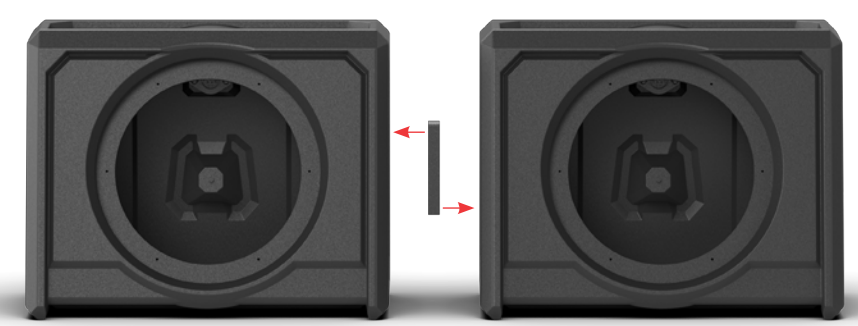

Shown conjoined, with **ZERO ENC** you can securely combine multiple enclosures with the included **Side Insert**.

- ZERO ENC**
- Heavy-Duty Roto-Molded Enclosure
 - Versatile Mounting Design
 - Quick Connect Wiring Harness
 - Structural Support for Subwoofer
 - Designed for Joining Multiple Enclosures

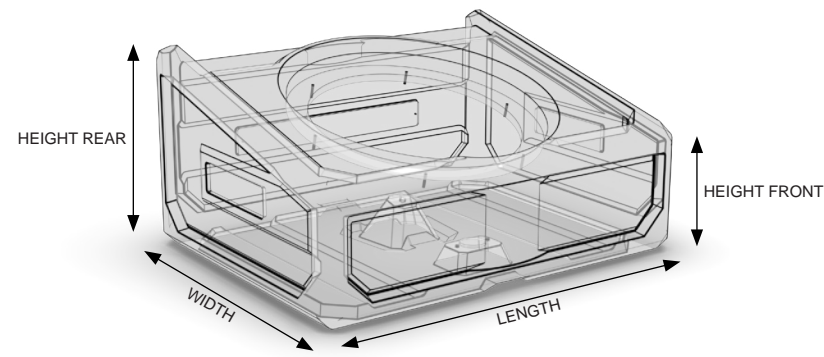

ZERO 10 ENC
 Width: 14" (355.60 mm)
 Length: 18" (457.20 mm)
 Height Front: 5.71" (145.03 mm)
 Height Rear: 8.81" (223.77 mm)

ZERO 12 ENC
 Width: 14" (355.60 mm)
 Length: 28" (711.20 mm)
 Height Front: 5.71" (145.03 mm)
 Height Rear: 8.81" (223.77 mm)

WET SOUNDS A-LINK PLUS

Wet Sounds A-Link plus is the world's first, full-wireless audio link system. With a new design & improved performance, you can broadcast from your system to multiple audio systems on any vehicle with an AUX input up to 1,600' without Bluetooth® or Wi-Fi. Each A LINK plus module can SEND or RECEIVE. When linking multiple units together, you will be able to create the ultimate party atmosphere no matter where you are on your boat, ATV, golf cart, or any other vehicle. A Link plus is must-have for any boat tie up!



- FEATURES INCLUDE:**
- No Bluetooth® or Wi-Fi connection needed
 - Operational Range – Approximately 1,600 feet
 - 3.5mm Connection cables & Y-adapter included
 - Each A Link Unit can be programmed to either SEND or RECEIVE
 - Multiple A Links can be set up to receive from 1 A Link Sender
 - Sender Standby Battery Time: 5.5 Hours
 - Receiver Standby Battery Time: 9.5 Hours
 - Dual Micro USB Charging Cable Included





WET SOUNDS GOLF CART AMPLIFIER KIT

Introducing the new Wet Sounds Golf Cart Amp Kit. This kit will allow for an easy installation of the STX Micro-4 amplifier on a golf cart when using the Wet Sounds (GC-H4S) Golf Cart 4-Speaker Wiring Harness. Utilizing 10 AWG power and ground wire, in-line fuse holder with 60-Amp Maxi type fuse, pre-crimped copper alloy ring terminals, wrapped in braided sleeving for a clean, professional look. Also included is a T-harness for easy connection with the Wet Sounds MC-2 or MC-20 radio that includes 20 AWG pigtail wiring for speaker connections on the STX Micro-4 amplifier.



GC-AMP-KIT

- Compatible with:
- GC-H4S (golf cart harness)
 - STX Micro 4 Amp
 - WS-MC-2
 - WS-MC-20

- FEATURES INCLUDE:
- 10 AWG power
 - In-line fuse holder
 - 60 Amp Maxi type fuse

WET SOUNDS GOLF CART HARNESS

The Wet Sounds Golf Cart 4-Speaker Wiring Harness allows easy installation of a four speaker system to your 4-seater golf cart without the headache of running all new wiring for all your hookups. The GC-H4S harness comes complete with plug-n-play connections that plug directly into your Wet Sounds REVO or RECON speakers. Including the RGB connections, as well as plug-n-play connections for power for the Wet Sounds MC-2 head unit and Stealth AS Series subwoofer.



GC-H45

- FEATURES INCLUDE:
- Easy Installation
 - Plug-n-Play Ready

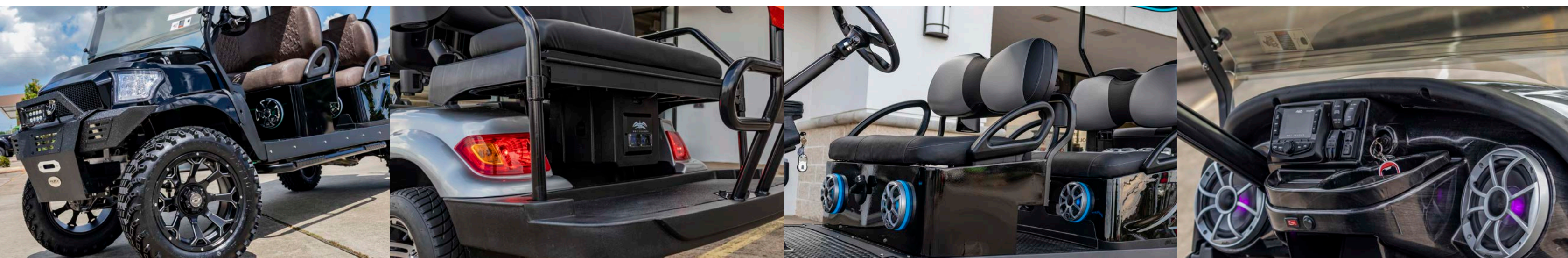

JEEP WRANGLER AUDIO KIT | Core Kit

Adventure starts with good tunes, that's why Wet Sounds™ developed a fully integrated pre-packaged solution for the 2018-2023 Jeep Wrangler. It has been designed and engineered for factory fit & finish and features a plug-and-play wire harness, all installation hardware and DSP tuned amplifier(s) that will provide you with the best sounding experience possible. Available in 2 options, a 1000W core kit to get your Jeep rockin' & an 800W tower kit for a combined 1800W of power for the ultimate jeep audio setup.

Features

- DSP Pre-Tuned Amplifier(s)
- Factory Style Wiring Harness
- Rotomolded Sub Enclosure - Lifiable for Storage Access
- In-Dash Enclosures - OE Fit
- Stylish Grilles to Flow with the OEM Look
- Level Control for Subwoofer & Optional Towers
- Optional Tower Upgrade

Available Models

- JEEP-JL-LVL1-C | Core Kit
- JEEP-JL-LVL2-T | Tower Kit - Add On



JEEP WRANGLER AUDIO KIT | Tower Add-On Kit

Take your new Jeep kit even further with the **JEEP-JL-LVL2-T** upgrade. With the tower upgrade, you'll get a pre-tuned SYN-DX DSP-OE amplifier, OE style wire harness with built-in RGB controller, TC-3 SXM clamps and a pair of REV 12 HD HLCD tower speakers, capable of up to 800W of pure mid-bass and highs that will take your Jeep game to the next level. Installation is simple, utilizing a factory fit bracket and our patent TC-3 SXM clamps to easily fasten or remove your speakers to keep a clean factory look when you need it.



JEEP-JL-LVL1-C

- (1) AMP Power Harness
- (1) Speaker Wire Harness
- (1) Distribution Block w/ Mounting Plate
- (1) 120A Fuse
- (2) Zero Series™ Tweeters w/ Trim Pieces
- (2) In-Dash Speaker Boxes
- (2) 6.5" Zero Series™ Coaxial Speakers
- (2) 6x9" Zero Series™ Coaxial Speakers
- (2) 6x9" Mounting Rings w/ Grille Trim Pieces
- (1) Amp/Sub Mounting Plate w/ Hardware
- (1) Sub Enclosure w/ Struts
- (2) 12" Zero Series™ 2Ω Subwoofers
- (1) SYN-DX6-DSP-OE Pre-Loaded Amplifier
- (1) LVL Control Module

JEEP-JL-LVL2-T

- (1) AMP Power Harness
- (1) Tower Speaker Wire Harness w/ Built-in RGB
- (1) 100A Fuse
- (2) REV HD Mounting Adapters
- (2) TC3 SXM Tower Mounts
- (2) 12" REV HD HLCD Tower Speakers
- (1) SYN-DX4-DSP-OE Pre-Loaded Amplifier
- (1) Tower LVL Control Dial



SHIVR-55 STEALTH 6 COOLER

The first ever of its kind! 55-liter, (58 quart) premium SHIVR® Cooler w/built-in 200 watt 6-speaker system. Complete with lithium-ion battery pack. Plays for over 8 hours - enough for any tailgate, picnic, or patio party. Available in 5 different colors.



FEATURES INCLUDE:

- Built-in Bluetooth®
- Auxiliary Input/Output
- AC Charger included & 12 Volt Charger
- Double-Wall Insulation
- Stealth 6-Speaker System with DSP
- Lockable Lid
- Capacity: 55 Liters/58 Quarts
- Built-in Lithium Ion Battery Pack (Up to 8 hours of play time)
- Rope Carry Handles and Rubber Latches
- W - 18.5" H - 18.5" L - 30"

Available Colors:



Connectivity

The SHIVR-55 can be connected in multiple ways: Bluetooth, Auxiliary cord or A Link Plus. The diagram to the right shows you the connections being used.

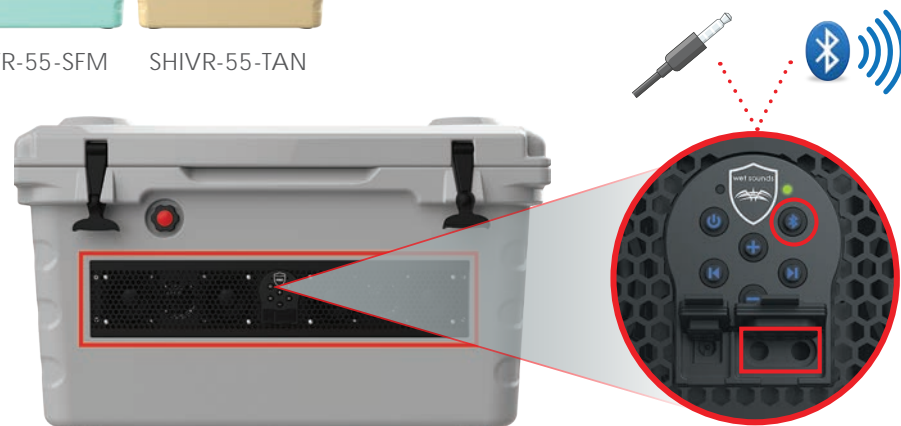

SHIVR SKINZ | GATOR STEP KITS

Fully customize your SHIVR-55 with GatorStep Foam-Traction kits. Available in two different kits: Standard and Deluxe. Both kits are available in 4 different color options for you to customize your SHIVR selection.



Deluxe Kit

5 Piece Set: Top, Front, Back, Right Side, and Left Side

Standard Kit

1 Piece Set: Top Only

SHIVR COOLER SKINZ

4 Color combinations





WET WIRE® | SPOOLED WIRE

Power wire, RCA cables, junction blocks, and fuse panels that resist the elements. Complete your system with wire and accessories designed specifically for marine and off-road applications.



WWX-3PRM-150
150 ft Spool 18 Gauge



WW-RGB 22G-150
150 ft Spool 22 Gauge RGB



WWX-8G BLK-250
250 ft Spool 8 Gauge Amp



WWX-4G BLK-125
125 ft Spool 4 Gauge Amp



WWX-SPKR/RGB Combo-150
150 ft Spool 6 Conductor



WWX-8G RED-250
250 ft Spool 8 Gauge Amp



WWX-1/0G BLK-50
50 ft Spool 1/0 Gauge Amp



WWX-4G Red-125
125 ft Spool 4 Gauge Amp



WWX-1/0G RED-50
50 ft Spool 1/0 Gauge Amp



WWX-SPK 12G-250
250 ft Spool 12 Gauge Speaker



WWX-SPK 14G-250
250 ft Spool 14 Gauge Speaker

- Spooled Frosted Bulk Wire
- 50ft - 500ft Spools
- True AWG Gauge Amp Wire

see more at
wetsounds.com

WET WIRE® | RCA CABLES

RCA Cables

- 2 - 6 Channel Quad Shielded
- High Contact RCA Tips
- Over Molded Jackets
- Individual Numbered Channels



RCA-6CH 23FT
23 ft 6 Channel RCA Cable



WWX-RCA F-2M Y
RCA Y Adapter Female to Male



WWX-RCA-3.5mm 2FT
RCA to 3.5mm - 2 Feet

see more at
wetsounds.com

WET WIRE® | USB SIGNALS, POWER BLOCKS



- Rubberized Protective Cover
- Over Molded Jackets

USB Signal Cables

see more at wetsounds.com

WET WIRE® | ACCESSORIES

see more at wetsounds.com



ST-DC-OEM
OEM Source Unit Adapter

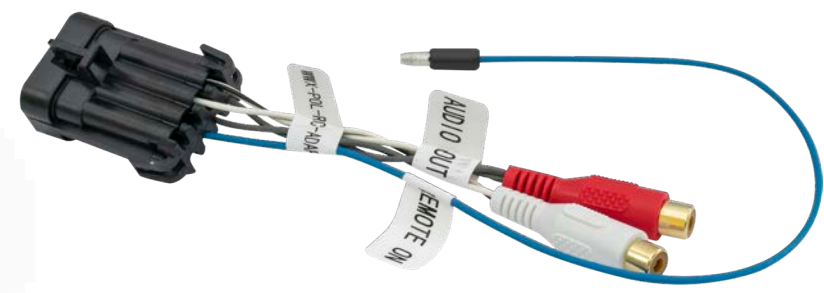

WWX-POL-RC-ADAP
Polaris Ride Command Adaptor

Fuse Distribution Blocks



- Enhanced Body Styling
- Versatility to use in many Applications
- Wire Fastening Points
- Adjustable Badge Orientation



see more at wetsounds.com



■ ANL 200 Fuse



■ ATC 8G Fuse



Amp Kits



WWX-ANTX







wet sounds®

High Performance Audio



Like & Follow Us Online!

www.wetsounds.com



WARNING:
Cancer and Reproductive Harm
www.P65Warnings.ca.gov